

# Service Manual

## Wok Induction **IWOKEC-3P / 1ZT**

[Art. 406600897]



# LIBERO LINE WOK INDUCTION

Document made by Product Care – Technical Training & Service – Vallenoncello PN/Italy

All the images and information of this document are property of ©Electrolux Professional Spa. This document and all its contents cannot be copied or used, in part or entirely without the written authorization of Electrolux Professional Spa.

## REVISIONS UPDATE:

EDITION	DESCRIPTION	DATE
1	First edition of Service Manual	APRIL. 2021

**Doc. N. 059785XW00**

**Edition 1 – 04-2021**

## Foreword



The service manual (here in after Manual) provides the engineer with information necessary for correct and safe care of the machine (here in after “machine”, “appliance” or “unit”).

The following instructions are intended to maintain the machine performance and to preventing injury to persons and animals and damage to property due to improper operating procedures.

All persons involved in machine transport, installation, commissioning and maintenance, repair and disassembly must refer to the content of this manual before carrying out the various operations. This, in order to avoid wrong and improper actions that could compromise the machine's integrity or endanger people.

If, after reading this manual, there are still doubts regarding machine use, do not hesitate to contact the Manufacturer or the Customer Care to receive prompt and precise assistance for better operation and maximum efficiency of the machine. During all stages of machine assessment, always respect the current regulations on safety, work hygiene and environmental protection. It is the user's responsibility to make sure the machine is started and operated only in optimum conditions of safety for people, animals and property.

### IMPORTANT

- The manufacturer declines any liability for operations carried out on the appliance without respecting the instructions given in this manual as well as for operations carried out by the user without respecting the instructions given in the user manual.
- The manufacturer reserves the right to modify the appliances presented in this publication without notice; manufacturer's relevant technical bulletins should be used as integration(s)/addendum(s).
- No part of this manual may be reproduced without the consent of the manufacturer
- This manual is available in digital format by:
  - contacting the reference customer care;
  - downloading the latest and up to date manual/technical bulletin(s) on the web site: [“www.electrolux.com/professional”](http://www.electrolux.com/professional).
  -

**The manual must always be part of the documentation available when servicing the machine.**

# LIBERO LINE WOK INDUCTION

## MODELS COVERED BY THE SERVICE MANUAL

Refer also to § DATA PLATE (IDENTIFICATION STICKER)

Pnc	Model	Type	Frequency Range (Hz)	Rated Voltage	Rated Input (kW)
600880	1PH - WOK - DI	LLWS1D	50-60	220-240 V 1N~	3,5
600892	1PH - WOK - DI	LLWS1D	50-60	220-240 V 1N~	3,5
600904	1PH - WOK - DI	LLWS1D	50-60	220-240 V 1N~	3
600881	1PH - WOK - SA	LLWS1S	50-60	220-240 V 1N~	3,5
600893	1PH - WOK - SA	LLWS1S	50-60	220-240 V 1N~	3,5
600905	1PH - WOK - SA	LLWS1S	50-60	220-240 V 1N~	3
600884	3PH - WOK - DI	LLWS3D	50-60	380-415 V 3N~	5
600896	3PH - WOK - DI	LLWS3D	50-60	380-415 V 3N~	5
600885	3PH - WOK - SA	LLWS3S	50-60	380-415 V 3N~	5
600897	3PH - WOK - SA	LLWS3S	50-60	380-415 V 3N~	5

**MODEL**= 1PH / 3PH = Phase - SZ= Single Zone - DZ= Double Zone - SA= Stand Alone - DI= Drop In

**TYPE**= LL=Libero Line - W= Wok - S = Single zone 1/3= Phase - S/D= Stand Alone/ Drop In

# LIBERO LINE WOK INDUCTION

INDEX

## INDEX

---

<b>1</b>	<b>GENERAL INFORMATION.....</b>	<b>7</b>
1.1	GENERAL INFORMATION .....	7
1.2	SAFETY INFORMATION/PRECAUTIONS.....	8
1.2.1	PERSONAL PROTECTION EQUIPMENT .....	9
1.2.2	GENERAL INFORMATION.....	9
1.2.3	RESIDUAL RISKS .....	10
1.3	DATA PLATE (IDENTIFICATION STICKER) .....	12
1.4	TECHNICAL DATA.....	13
1.5	OVERALL DRAWINGS WITH MEASUREMENTS.....	14
1.6	CONTROL PANEL INTERFACES.....	16
1.7	DEFINITIONS/GLOSSARY .....	17
<b>2</b>	<b>INSTALLATION AND COMMISSIONING .....</b>	<b>18</b>
2.1	GENERAL INSTALLATION.....	18
2.1.1	UNPACKING AND POSITIONING THE EQUIPMENT.....	18
2.1.2	ROOM REQUIREMENTS.....	18
2.1.3	LIMITATIONS.....	19
2.1.4	LIST OF POSSIBLE INSTALLATION SOLUTIONS .....	19
2.1.4.1	ON BASE / REFRIGERATED BASE.....	19
2.1.4.2	ON LIBERO POINT .....	19
2.1.4.3	DROP IN.....	20
2.1.4.3.1	DIMENSIONS & AIR REQUIREMENTS.....	21
2.1.5	APPLIANCE REQUIREMENTS.....	22
2.1.5.1	POWER (VOLTS).....	22
2.1.5.2	AIR CIRCULATION .....	22
2.1.5.3	APPLIANCE LOAD.....	22
2.2	ELECTRIC CONNECTION.....	23
2.3.1	HOW TO RECOGNIZE PHASE AND NEUTRAL .....	24
2.3.2	RESIDUAL CURRENT.....	24
2.4	FIRST START UP.....	25
2.4.1	DAILY STARTUP .....	25
2.5	COMMISSIONING.....	25
<b>3</b>	<b>USE OF APPLIANCE .....</b>	<b>26</b>
3.1	OPERATING INSTRUCTIONS.....	26
3.2	CLEANING.....	27
3.2.1	APPLIANCE & GLASS TOP SURFACE.....	27
3.2.2	AIR FILTERS.....	27
<b>4</b>	<b>DETAILED APPLIANCE AND COMPONENTS DESCRIPTION/FUNCTIONING .....</b>	<b>28</b>
4.1	FUNCTIONAL / TECHNICAL DESCRIPTION.....	28
4.2	EQUIPMENT FUNCTIONING .....	28
4.3	AIR CIRCULATION.....	28
4.4	COMPONENTS, DESCRIPTION/FUNCTIONING, APPLIANCE 3500W .....	29

---

# LIBERO LINE WOK INDUCTION

4.4.1	GENERATOR TESLA, POW .....	29
4.4.2	VENTILATOR.....	30
4.4.3	AIR FILTER .....	31
4.4.4	VENTILATOR (TANGENTIAL) M1 .....	31
4.4.5	USER INTERFACE, U.I .....	32
4.4.6	COILS & TEMPERATURE SENSORS,.....	33
4.5	COMPONENTS, DESCRIPTION/FUNCTIONING, APPLIANCE 5000W .....	34
4.5.1	GENERATOR FOUCAULT - COILS & TEMPERATURE SENSOR.....	34
4.5.2	USER BOARD, U.I.....	35
4.6	INDUCTION POTS, PRECAUTIONS .....	35
4.7	PERFORMANCE .....	36
4.7.1	POWER TABLE 1PH-WOK .....	37
4.7.2	POWER TABLE 3PH-WOK .....	37
4.8	ELECTRONIC BOARD .....	38
4.8.1	SWITCHING ON / OFF .....	38
4.8.2	CUSTOMER MENU .....	39
4.8.2.1	BUZZER MODE.....	41
4.8.2.2	HOB2HOOD MODE .....	42
4.8.2.3	ALARM HISTORY .....	43
4.8.3	SERVICE MENU .....	44
4.8.3.1	DEMO MODE .....	46
4.8.3.2	SI, SOFTWARE EDITION .....	47
4.8.3.3	S2, SELF-DIAGNOSTIC TEST OF GENERATORS OFF.....	49
4.8.3.4	S3, SELF-DIAGNOSTIC TEST WITH GENERATORS ON .....	52
4.8.3.5	S4, COOKING TOP COUPLING .....	55
4.8.4	HOB TO HOOD (H2H, SPECIAL FUNCTION) .....	58
4.8.5	MANUAL FAN SPEED .....	58
4.8.6	AUTOMATIC FAN SPEED:.....	59
4.8.7	ALARMS.....	61
4.8.7.1	ALARM CODE LIST .....	63
4.9	SOFTWARE UPDATE & WIFI.....	65
<b>5</b>	<b>TROUBLESHOOTING .....</b>	<b>66</b>
5.1	ALARM TROUBLESHOOTING .....	66
<b>6</b>	<b>SERVICING THE APPLIANCE.....</b>	<b>66</b>
6.1	LIST OF NEEDED TOOLS .....	66
6.2	DISASSEMBLY/REASSEMBLE OF COMPONENTS .....	67
6.2.1	APPLIANCE CASING .....	68
6.2.2	COMPONENTS APPLIANCE 3500W.....	69
6.2.2.1	GENERATOR POB TESLA .....	69
6.2.2.2	VENTILATOR .....	70
6.2.2.3	AIR FILTERS .....	70
6.2.2.4	USER INTERFACE, U.I. & VENTILATOR (TANGENTIAL) .....	71
6.2.2.5	COILS .....	72

# LIBERO LINE WOK INDUCTION

6.2.3	COMPONENTS APPLIANCE 5000W .....	72
6.2.3.1	GENERATOR FOUCAULT.....	73
6.2.3.2	AIR FILTERS .....	74
6.2.3.3	USER BOARD .....	74

# LIBERO LINE WOK INDUCTION

## 1 GENERAL INFORMATION

---

### 1.1 GENERAL INFORMATION

To ensure safe use of the machine and a proper understanding of the manual it is necessary to be familiar with the terms and typographical conventions used in the documentation. The following symbols are used in the manual to indicate and identify the various types of hazards:

 **WARNING**  
Danger for the health and safety of operators.

 **WARNING**  
Danger of electrocution - dangerous voltage.

 **CAUTION**  
Risk of damage to the machine or the product.

 **WARNING**  
Danger of magnetic fields.

 **IMPORTANT**  
Important instructions or information on the product

 Read the instructions before using the appliance

 Clarifications and explanations

- Only specialized personnel are authorized to operate on the machine.
- This appliance must not be used by minors and adults with limited physical, sensory or mental abilities or without adequate experience and knowledge regarding its use.
  - Do not let children play with the appliance.
  - Keep all packaging and detergents away from children.
  - Cleaning and user maintenance shall not be made by children without supervision.
- Do not store explosive substances, such as pressurized containers with flammable propellant, in this appliance or close to the appliance
- Do not remove, tamper with or make the machine “CE” marking illegible.
- Refer to the data given on the machine’s data plate “CE” marking for relations with the Manufacturer (e.g. when ordering spare parts, etc.).
- When scrapping the machine, the “CE” marking must be destroyed.

# LIBERO LINE WOK INDUCTION

## 1.2 SAFETY INFORMATION/PRECAUTIONS





- Risks mainly of a mechanical, thermal and electrical nature exist in the machine. Where possible the risks have been neutralized:
  - directly, by means of adequate design solutions.
  - indirectly by using guards, protection and safety devices.
- During maintenance several risks remain, as these could not be eliminated, and must be neutralized by adopting specific measures and precautions.
- Do not carry out any checking, cleaning, repair or maintenance operations on moving parts. Workers must be informed of this prohibition by means of clearly visible signs.
- To guarantee machine efficiency and correct operation, periodical maintenance must be carried out according to the instructions given in this manual.
- Make sure to periodically check correct operation of all the safety devices and the insulation of electrical cables, which must be replaced if damaged.
- Extraordinary machine maintenance operations must only be carried out by specialized Technicians provided with all the appropriate personal protection equipment (safety shoes, gloves, glasses, overalls, etc.), tools, utensils and ancillary means.
- Never operate the machine, removing, modifying or tampering with the guards, protection or safety devices.
- Before carrying out any operation on the machine, always consult the manual which gives the correct procedures and contains important information on safety.



# LIBERO LINE WOK INDUCTION

## 1.2.1 PERSONAL PROTECTION EQUIPMENT

Summary table of the **Personal Protection Equipment (PPE)** to be used during the various stages of the machine's service life.

Stage	Protective garments 	Safety footwear 	Gloves 	Glasses 	Safety helmet 
Transport	—	●	○	—	○
Handling	—	●	○	—	—
Unpacking	—	●	●	—	—
Installation	—	●	● <sup>2</sup>	●	—
Normal use	●	●	● <sup>1</sup>	○	—
Adjustments	○	●	○	○	—
Routine cleaning	○	●	● <sup>1 or 2</sup>	○	—
Extraordinary cleaning	○	●	● <sup>1 or 2</sup>	○	—
Maintenance	○	●	○	○	—
Dismantling	○	●	○	○	—
Scrapping	●	●	●	●	—
<b>Key:</b>					
●	<b>PPE REQUIRED</b>				
○	<b>PPE AVAILABLE OR TO BE USED IF NECESSARY</b>				
—	<b>PPE NOT REQUIRED</b>				

1. During these operations, the worn gloves must be heatproof to protect hands from contact with hot food or hot parts of the appliance and/or when removing hot items from it. Failure to use the personal protection equipment by operators, specialized personnel or users can involve exposure to chemical risk and possible damage to health (depending on the model).
2. During these operations, the worn gloves must be cut-resistant. Failure to use the personal protection equipment by operators, specialized personnel or users can involve exposure to damage to health (depending on the model).

## 1.2.2 GENERAL INFORMATION

- The machines are provided with electric and/or mechanical safety devices for protecting workers and the machine itself. Therefore, the user must not remove or tamper with such devices. The Manufacturer declines any liability for damage due to tampering or their non-use.
- Never operate the machine, removing, modifying or tampering with the guards, protection or safety devices.
- Do not make any modifications to the parts supplied with the appliance.
- Several illustrations in the manual show the machine, or parts of it, without guards or with guards removed. This is purely for explanatory purposes. Do not use the machine without the guards or with the protection devices deactivated.
- Do not remove, tamper with or make illegible the safety, danger and instruction signs and labels on the machine.

# LIBERO LINE WOK INDUCTION

- Air recirculation must take into account the air necessary for combustion, 2 m<sup>3</sup>/h/kW of gas power, and also the "well-being" of persons working in the kitchen.
- Inadequate ventilation causes asphyxia. Do not obstruct the ventilation system in the place where this appliance is installed. Do not obstruct the vents or ducts of this or other appliances.
- Place emergency telephone numbers in a visible position.
- The measured sound level emitted "A" does not exceed 70 dB ("A").
- Turn the appliance off in case of fault or poor operation.
- Do not use products (even if diluted) containing chlorine (sodium hypochlorite, hydrochloric or muriatic acid, etc.) to clean the appliance or the floor under it.
- Do not use metal tools to clean steel parts (wire brushes or Scotch Brite type scouring pads).
- Do not allow oil or grease to come into contact with plastic parts. Do not allow dirt, fat, food or other residuals to form deposits on the appliance.
- Do not spray water or use steam to clean the equipment.
- Do not store or use gasoline or other flammable vapors, liquids or items in the vicinity of this or any other appliance.
- Do not spray aerosols in the vicinity of this appliance while it is in operation.
- Never check for leaks with an open flame.

## 1.2.3 RESIDUAL RISKS

- The machine has several risks that were not completely eliminated from a design standpoint or with the installation of adequate protection devices. Nevertheless, through this manual the Manufacturer has taken steps to inform operators of such risks, carefully indicating the personal protection equipment to be used by them. Sufficient spaces are provided for during the machine installation stages in order to limit these risks.

To preserve these conditions, the areas around the machine must always be:

- kept free of obstacles (e.g. ladders, tools, containers, boxes, etc.);
- clean and dry;
- well lit.

For the Customer's complete information, the residual risks remaining on the machine are indicated below: such actions are deemed improper and therefore strictly forbidden.

Residual risk	Description of hazardous situation
Slipping or falling	The operator can slip due to water or dirt on the floor
Burns/abrasions (e.g. heating elements)	The operator deliberately or unintentionally touches some components inside the machine without using protective gloves
Electrocution	Contact with live parts during maintenance operations carried out with the electrical panel powered
Sudden closing of the lid/ door/oven door (if present, depending on the appliance type)	The operator for normal machine use could suddenly and deliberately close the lid/door/oven door (if present, depending on the appliance type)
Tipping of loads	When handling the machine or the packing containing it, using unsuitable lifting systems or accessories or with the load unbalanced

### Mechanical safety characteristics, hazards





- The appliance does not have sharp edges or protruding parts. The guards for the moving and live parts are fixed to the cabinet with screws, to prevent accidental access.





### Protection devices installed on the machine

- The guards on the machine are:
  - fixed guards (e.g. casings, covers, side panels, etc.), fixed to the machine and/or frame with screws or quick-release connectors that can only be removed or opened with tools

# LIBERO LINE WOK INDUCTION

## Safety signs to be placed near the machine area

Prohibition	Meaning
	do not remove the safety devices
	do not use water to extinguish fires (placed on electrical parts)
	Keep the area around the appliance clear and free from combustible materials. Do not keep flammable materials in the vicinity of the appliance
	Install the appliance in a well-ventilated place to avoid the creation of dangerous mixtures of unburnt gases in the same room

Danger	Meaning
	danger of burns
	danger of electrocution (shown on electrical parts with indication of voltage)
	risk of electromagnetic fields
	Access forbidden to wearers of electrical stimulators (pacemakers)

### End of use

When the appliance is no longer to be used, make it unusable by removing the mains power supply wiring.

# LIBERO LINE WOK INDUCTION

## 1.3 DATA PLATE (IDENTIFICATION STICKER)

The identification sticker is located on the bottom of the appliance. The meaning of the various information is listed below:

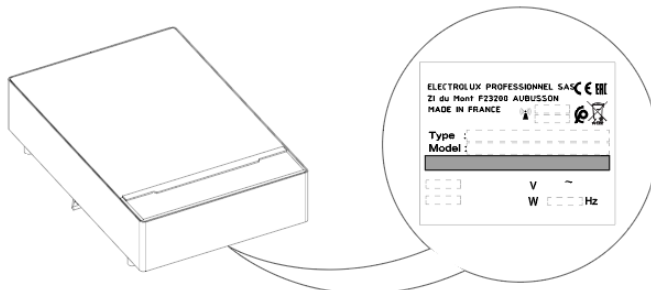

### EXAMPLE PICTURE !

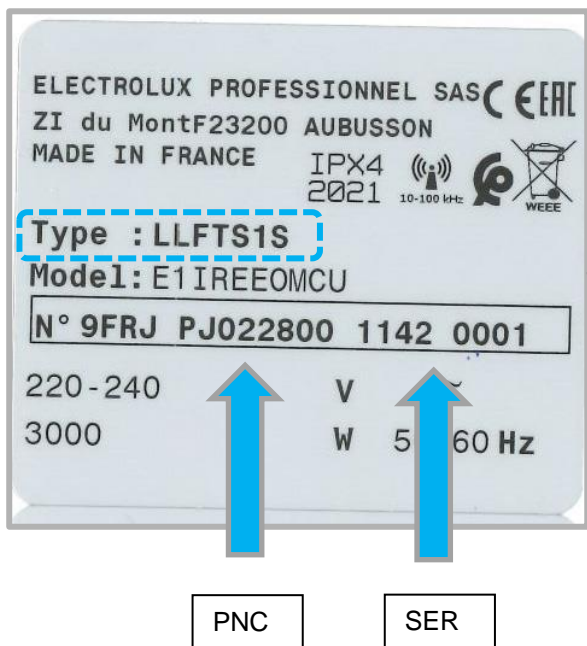

SERIAL NUMBER (PRODUCTION DATE) is necessary to find the correct spare part or to ask tech. support.

**EXAMPLE : Serial Number**  
**1 14 2 0001**

4<sup>th</sup> Digit of current year

3<sup>th</sup> Digit of current year

Week

Progressive number of construction

1
14
2
0001

Serial nr

**EXAMPLE : TYPE**  
**LL FT S 1 S**

<b>1 - Product / Brand</b>	
LL	Libero Line
<b>2 - Function Type</b>	
F	Flat
W	Wok
FT	Fry Top
<b>3 - Size / zones</b>	
S	Single zone
D	Double zone
<b>4 - Power Supply / Phases</b>	
1	1 Phase
3	3 Phases
<b>5 - Module Type</b>	
S	Stand Alone
D	Drop In

# LIBERO LINE WOK INDUCTION

## 1.4 TECHNICAL DATA

Induction Wok				
Type		LLWS1S LLWS1D		LLWS3S LLWS3D
Appliance description		Single Zone	Single Zone (UK)	Single Zone
Power supply voltage	V	220 – 240		380 — 415
Frequency	Hz.	50 – 60		50 – 60
Phases	Nr.	1N~		3~

Induction Wok				
Type		LLWS1S LLWS1D		LLWS3S LLWS3D
Appliance description		Single Zone	Single Zone (UK)	Single Zone
Max current	A	16	13	7
Max total power	kW	3.5	3	5
Plug	Type	F (Schuko)	G	3N+PE 16A (IEC 60309)

**TYPE=** LL=Libero Line - W= Wok - S = Single zone 1/3= Phase - S/D= Stand Alone/ Drop In

# LIBERO LINE WOK INDUCTION

## 1.5 OVERALL DRAWINGS WITH MEASUREMENTS

1PH / 3PH = Phase - SZ= Single Zone - DZ= Double Zone - SA= Stand Alone - DI= Drop In  
**1PH WOK SA**

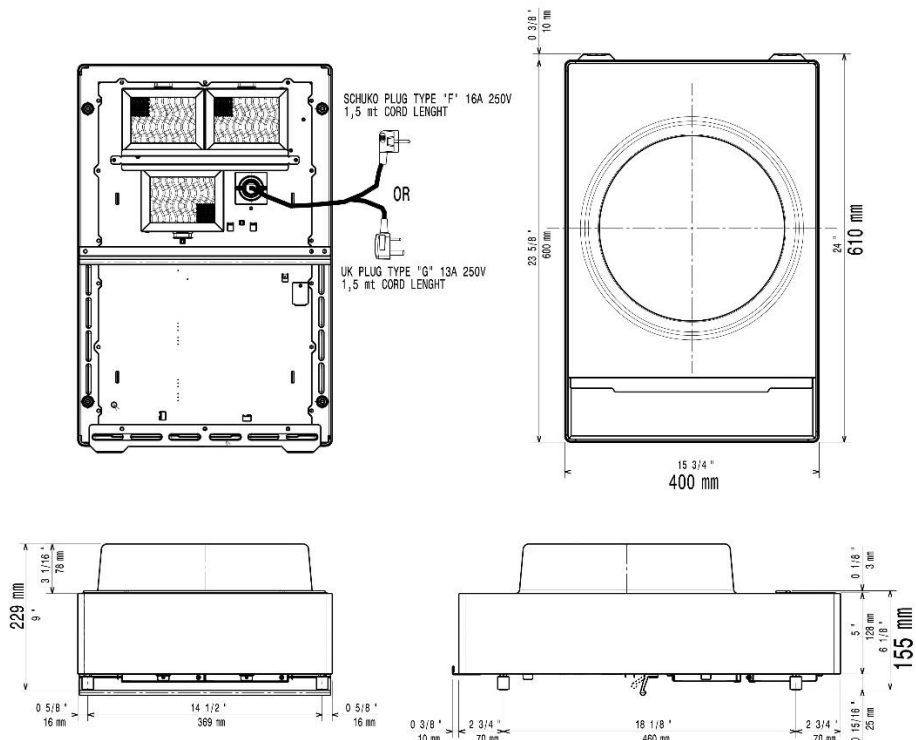

## 1PH WOK DI

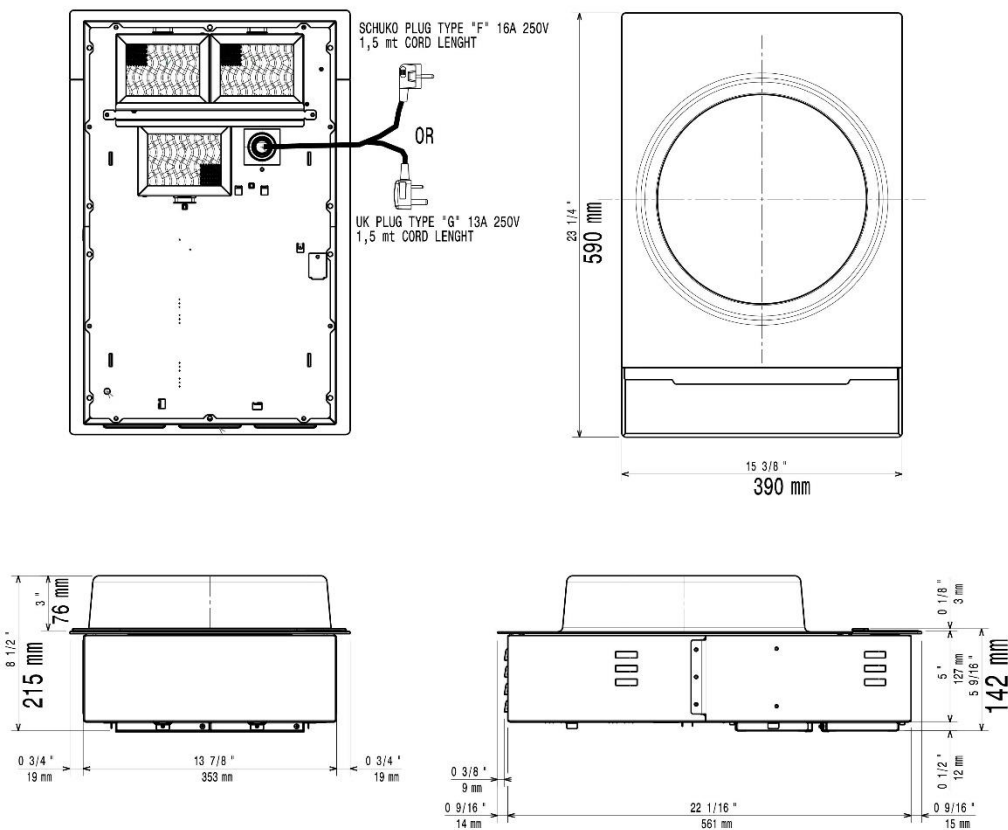

# LIBERO LINE WOK INDUCTION

## 3P WOK SA

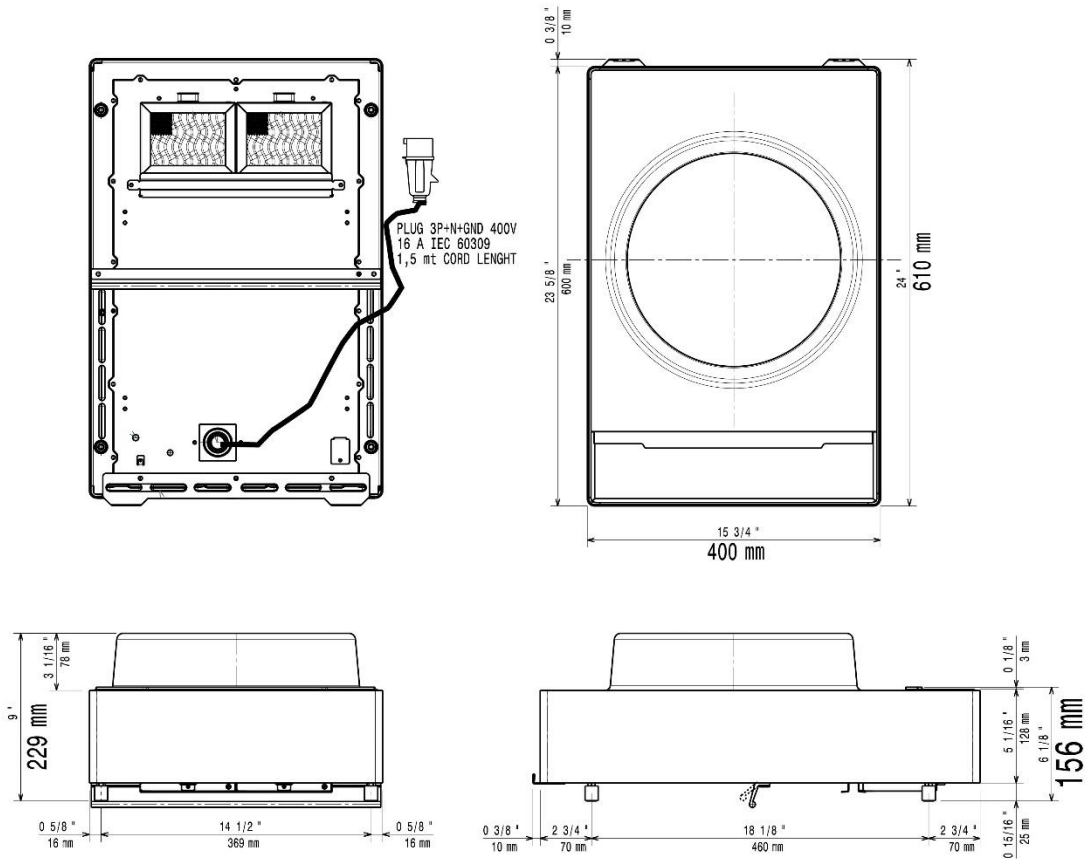

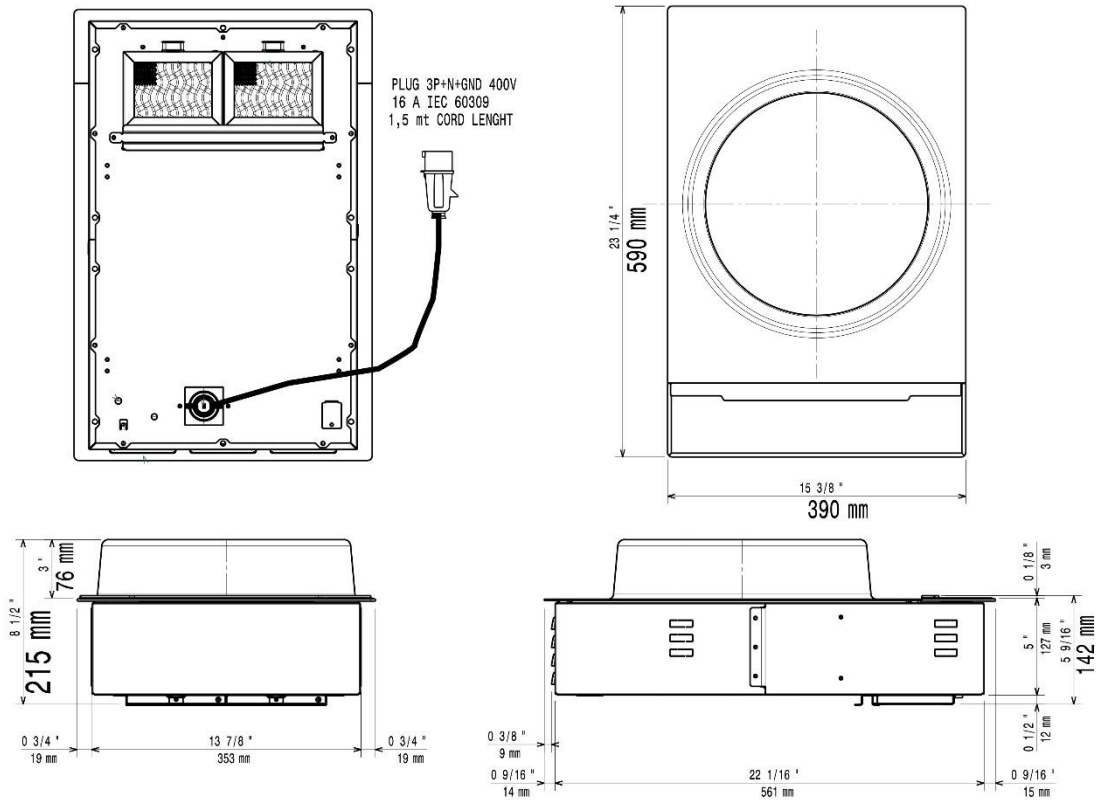

## 3PH SZ DI



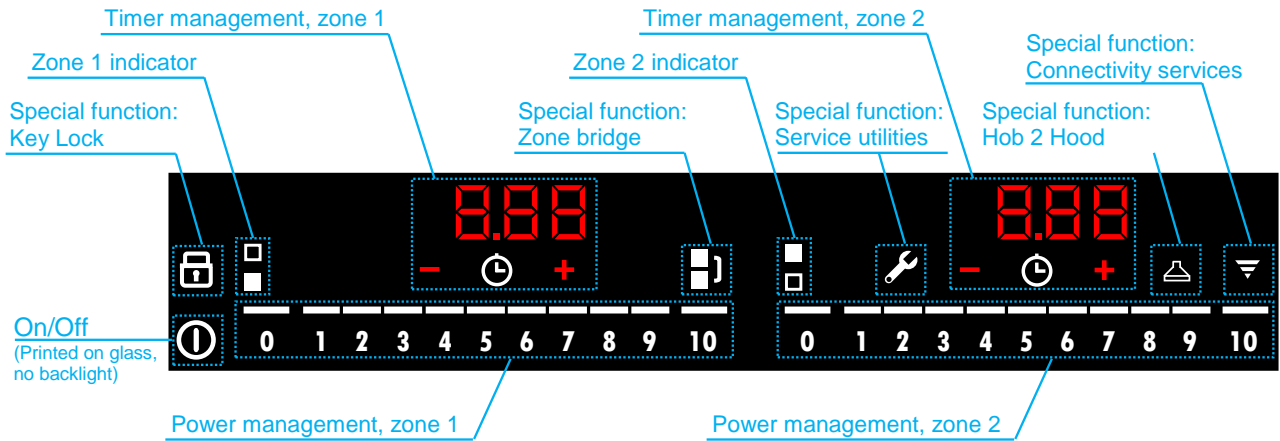

# LIBERO LINE WOK INDUCTION

## 1.6 CONTROL PANEL INTERFACES



**ON /OFF**  Touch the button: the griddle will turn on; a lamp test will occur, and the zone will then be ready for temp regulation/setting.

**LOCK**  It is possible to lock the control panel while the cooking zones are in operation, in order to prevent accidental changes of the power level. To activate the function, press the button for three seconds; the corresponding indicator turn red and blinks. To deactivate the function, touch the button again; the previously set power level lights up.

**COOKING ZONES**  Front,  Rear



**POWER MANAGMENT** the power output regulation can be set by pressing the sliding bar or pressing on the “plus / minus”

**TIMER DISPLAY** 

**MERGED ZONES MODE**  Pressing the button the cooking zones will be merged and will be operable through the left side hand touch panel only.



# LIBERO LINE WOK INDUCTION



**HOOD TO HOB** (only with coupled Libero Point appliances) This is an advanced automatic function that connects the hob to the Libero Point's hood. Both the hob and the hood have an infrared signal communicator. The fan speed is automatically set based on the mode settings and the temperature of the hottest pan on the hob. It is also possible to operate the fan from the hob manually pressing one to four times the button.



**WIRELESS** to be implemented.

## 1.7 DEFINITIONS/GLOSSARY

**POW** Induction Power Board. Sometimes referred also as “Hob Control” (HC) or “POB”

**HC** Hob Control, sometimes referred also as “Power Board” (POW).

**TESLA** Single-phase, Double generator, 3500W Induction Power Board.

**FOUCAULT** 3-phase, Single generator, 5000W Induction Power Board.

**UI** User Interface

**HUI** Hob User Interface

**ROADRUNNER** User Interface

**PD or HPD** Hob Pot Detection. A circuit, normally embedded in a POW, able to detect pot presence over a coil.

**HOB** Induction Hob cooking appliance

**WOK** Induction WOK cooking appliance

**FRY** Induction Fry Top cooking appliance

**SZ** Single Zone (cooking appliance)

**DZ** Double Zone (cooking appliance)

**SA** Stand Alone

**DI** Drop In

**1PH** Single-phase power supply line

**3PH** 3-phase power supply line

**MACS** Mayor Appliance Communication System. A communication protocol used in Electrolux commercial appliances.

**HCS** Hob Communication System protocol. A MACS-based protocol variant, especially dedicated to Hob appliances.

**DAAS** Data Acquisition protocol. A MACS-based protocol variant, especially dedicated to exchange raw data between electronic devices/boards.

**APD** Disconnection relay. Power relay, belonging to POW circuits that supplies power to the induction circuits.

**SW** Software

**HW** Hardware

§ = chapter / paragraph

**MACHINE** or “appliance“ or “unit”

# LIBERO LINE WOK INDUCTION

## 2 INSTALLATION AND COMMISSIONING

---

### 2.1 GENERAL INSTALLATION

All the non-standard or out-of-standard situations should be reported on the commissioning form and duly documented for future reference. The documentation available on the web sites (PRIDE-SERVICE PORTAL-AGELUX etc..) In case of any doubt, refer to your local country customer care.

#### 2.1.1 UNPACKING AND POSITIONING THE EQUIPMENT



##### WARNING / CAUTION !

Before any operation on the machine read Chapter [SAFETY INFORMATION/PRECAUTIONS](#). We recommend for any phase involving the removal of the packaging to use cut-resistant gloves



#### 2.1.2 ROOM REQUIREMENTS

To guarantee continuous operation, the room temperature range must be between **5°C and 40°C**. Outdoor functioning is strictly allowed only if the machine can be protected against any conditions being out of the above temperature range and against any atmospheric agents.

On a hot cupboard base take precaution to install a baffle for preventing hot air to reach the oven fresh air intake; this could create malfunctioning.

High room humidity may cause water to condensate on electric components hence causing short circuit.

# LIBERO LINE WOK INDUCTION

## 2.1.3 LIMITATIONS

Induction appliances: to guarantee continuous operation at maximum power, the room temperature must be below 40°C.

Drop in appliances have air intake limitations, please refer to § [AIR REQUIREMENTS](#)

## 2.1.4 LIST OF POSSIBLE INSTALLATION SOLUTIONS

Hereinafter, the instructions for the main installation possibilities. The different accessories have a dedicated Installation Manual; please refer also to these documents provided with the accessories or available on PRIDE.

### 2.1.4.1 ON BASE / REFRIGERATED BASE

All Stand-alone appliances can be fixed onto bases.

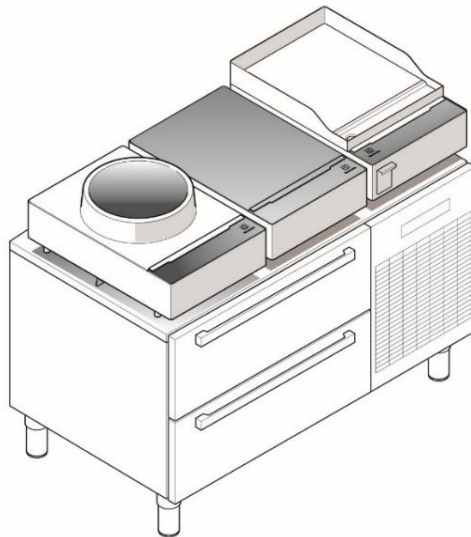

### 2.1.4.2 ON LIBERO POINT

The Stand-alone appliances can be installed into the libero point

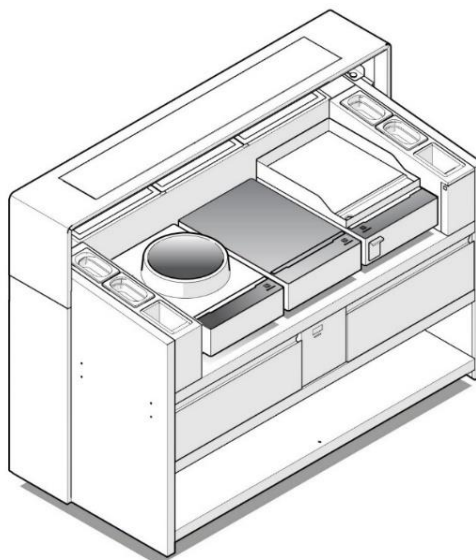

# LIBERO LINE WOK INDUCTION

## 2.1.4.3 DROP IN

All appliances, except fry tops, are available with a specific PNC code as “drop in “ D.I., model.

### Example picture of a D.I HOB.

- 1-Apply a sponge gasket type to the top surface. We recommend to not use silicone , this because it could complicate any future extraction.
- 2-The fixing assembly can be inserted into the three different precut slots (1,2,3) depending on the thickness of the top.
- 3- Fixing assembly installed
- 4- Tighten the screw to blocking the appliance into place
- 5- End result

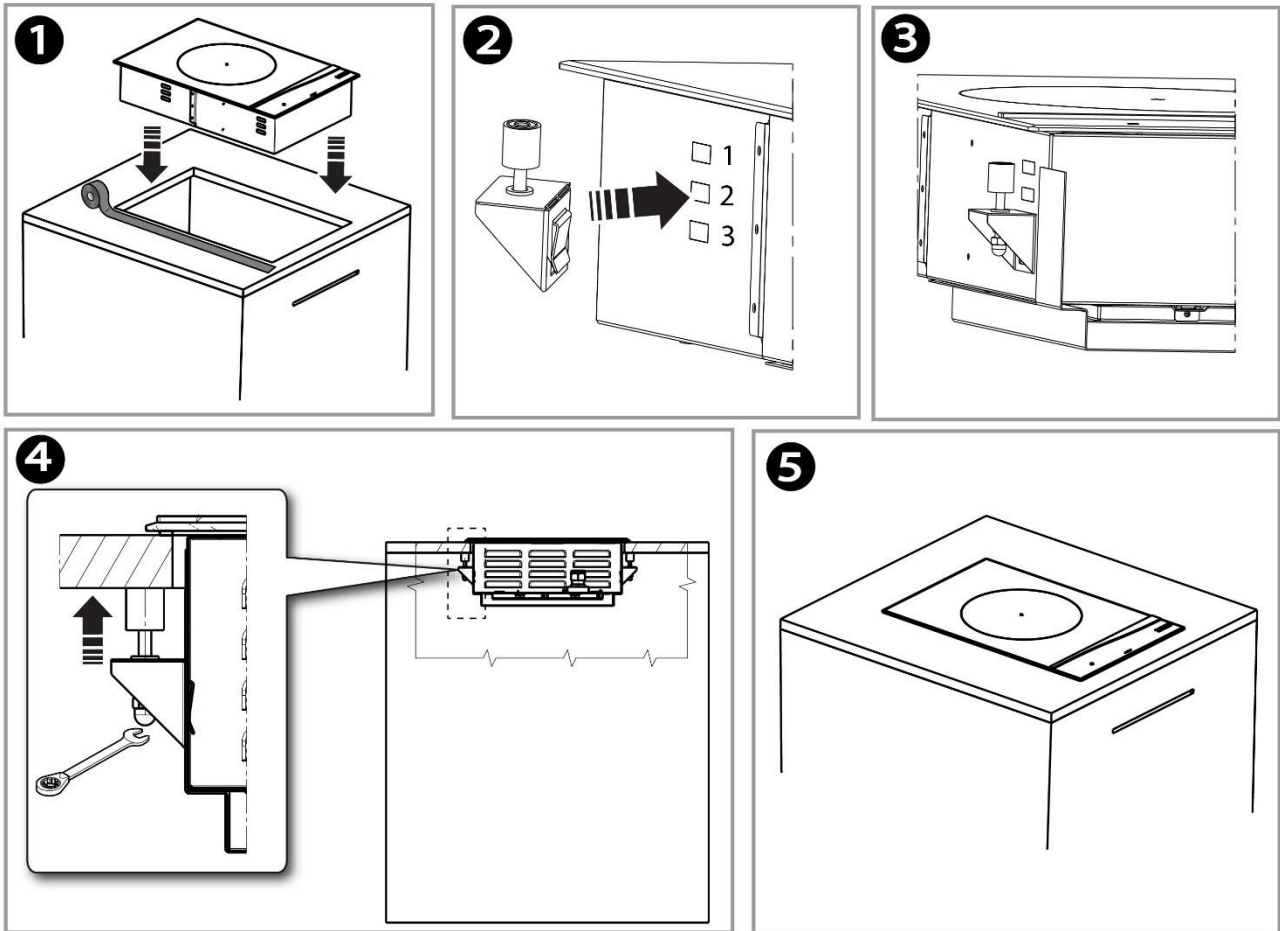

Pictures are examples for installation purposes.



### NOTE !

The sponge gasket, fixing assembly and air conveyor are not supplied with the drop-in appliance, they are accessories and must be ordered separately.

# LIBERO LINE WOK INDUCTION

## 2.1.4.3.1 DIMENSIONS & AIR REQUIREMENTS

The appliance is predisposed for an air inlet conveyor that is not supplied with the appliance. Minimum air intake slot to be arranged on the furniture is 3000MM<sup>2</sup>; if a sufficient cool air intake cannot be assured to the appliance there could be generated an overheating alarm message notification, refer to § [ALARM CODE LIST](#)

Please refer to the Installation and Operating Manual of this accessory for further installation instructions.

All documents are available for authorized technicians on the web sites (PRIDE-SERVICE PORTAL- AGELUX etc..) In case of any doubt, refer to your local country customer care.

Here is an example image of the conveyor installed.

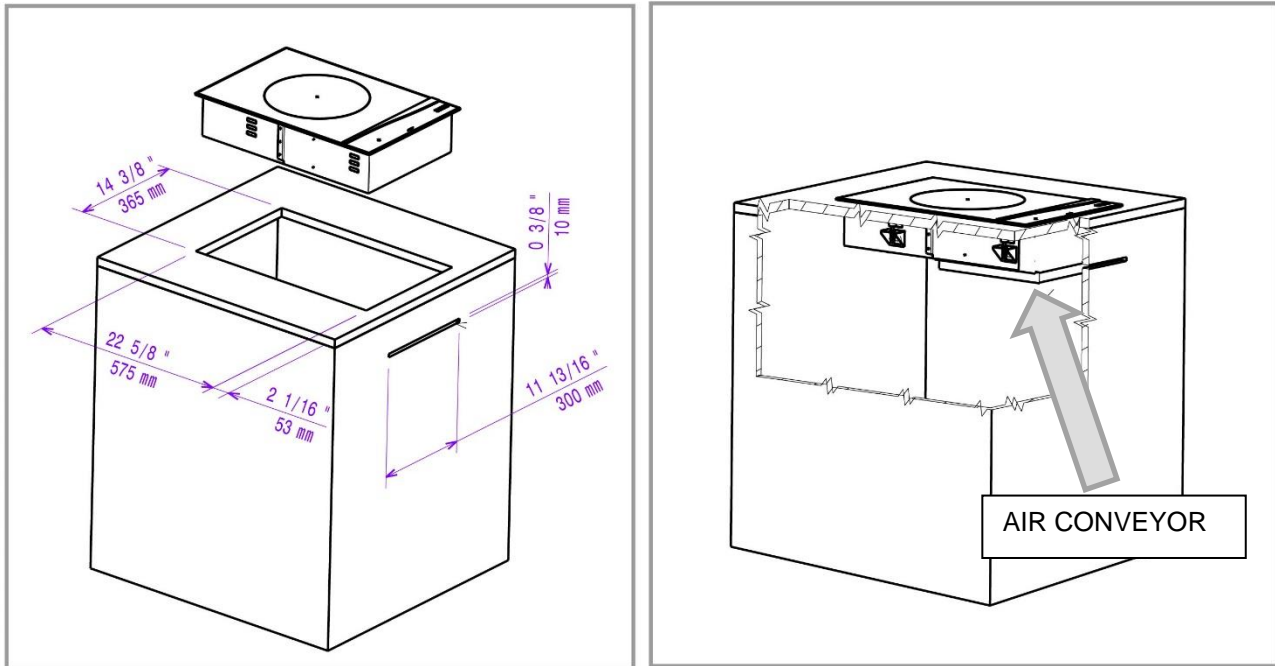

### NOTE !

The sponge gasket, fixing assembly and air conveyor are not supplied with the drop-in appliance, they are accessories and must be ordered separately.

In case you intend to "self-make" an air conveyor, it is strongly recommended to keep the possibility for a quick access to the intake air filters for ordinary maintenance.

# LIBERO LINE WOK INDUCTION

## 2.1.5 APPLIANCE REQUIREMENTS

### 2.1.5.1 POWER (VOLTS)

Refer to the volts range data indicated in the tech specs table § [TECHNICAL DATA](#)

### 2.1.5.2 AIR CIRCULATION

The appliance does not have aeration slots on the top surface; underneath is located the inlet / outlet passage slots. The inlet passage is also equipped with removable metal mesh filters that can be removed to be washed with warm water and soap.

Drop in appliances have air intake limitations, please refer to § [AIR REQUIREMENTS](#)

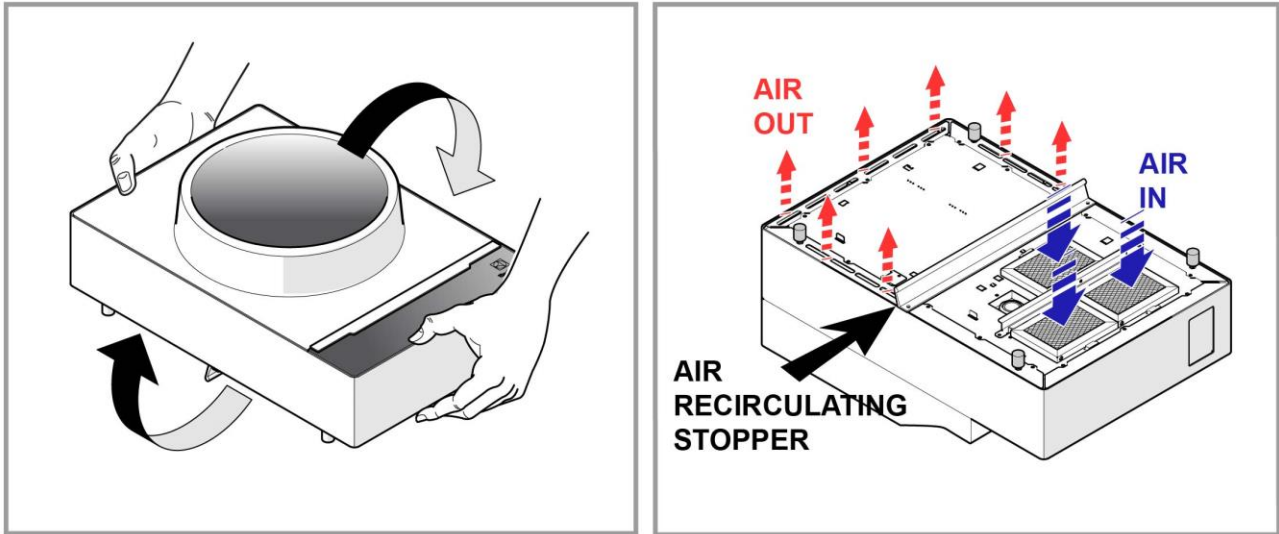

### 2.1.5.3 APPLIANCE LOAD

It is possible to "load" the appliances with a total weight of 40kg distributed across the surface in pots suitable for induction use and of a max diameter of 28cm.



#### **WARNING!**

Bigger diameter pots than those indicated, if detected by more than one zone (valid only for two zone appliances) could damage the generators. It is also **not suggested** to let the pot rest on the border stainless top, it must fit only on top of the glass.

EXAMPLE: Let's do some considerations for a cooking zone: For example a standard pot used in professional cooking would be a pot of 30cm diameter (so the bottom would be approx. 28cm) and if it was 25cm high it would contain approx. 18 liters of water, add like 2kg for the pot, that would make 20kg (pot and water)..... if you multiply per 2 zones= 40kg... approx.

# LIBERO LINE WOK INDUCTION

## 2.2 ELECTRIC CONNECTION



### WARNING !

Take GREAT CARE when connecting / testing anything with live current, if you are unsure what you are doing and how to use your equipment safely, then **DON'T DO IT.**



### IMPORTANT !

The connection to the electrical power supply must be in compliance with the current national and local regulations

The “single zone and double zone” appliances are “plug in” and are equipped with a socket ready to be inserted into mains supply.

Install ahead of the appliance an omni polar switch of suitable capacity with contact opening distance of at least 3 mm. Insert the plug into the building's electrical system, in the immediate vicinity of the appliance.

Appliance max. leakage current is 5 mA.

Install ahead of the appliance a device (interlocked plug, lockable switch or similar devices) lockable in the open position during maintenance. Connect the appliance to an efficient earthing system.

Include also the appliance into an equipotential system. The equipotential terminal block is located under the

appliance and is marked



### CAUTION / IMPORTANT !

If the supply cord is damaged, it must be replaced in order to avoid a hazard. The manufacturer declines any liability if the current national and local regulations and possible safety regulations are not respected

# LIBERO LINE WOK INDUCTION

## 2.3.1 HOW TO RECOGNIZE PHASE AND NEUTRAL



### WARNING!

Take GREAT CARE when testing anything with live current and always use your personal protective equipment; if you are unsure what you are doing and how to use your equipment safely then **DON'T DO IT**

The appliance is equipped with a power cord and socket, however, in case of need, some basic tips on how to check the supply wires before our main terminal board.

**Double zone appliances are three phase supplied : L1+L2+L3 +N**

**Single zone is single phase supplied: L+N**

Put your meter in AC Volts setting. Connect supply to the main terminal board **MA** but do not turn on the appliance. Connect the meter test leads to the terminal board contacts; the readings should be:

L1 / L2 / L3 + N\* (Phase and Neutral) = **230 Volts**  
(+/- 6% based on European standards)

L1 / L2 / L3 +  $\perp$  (Phase and Earth) = **230 Volts**

L1 and/or L2 + L3 (Phase and Phase) = **400 Volts**

N +  $\perp$  (Neutral and Earth) = **0 Volts**  
(or approx. zero V)

The combination and results obtained will permit you to find all wires: PHASE, NEUTRAL and EARTH.

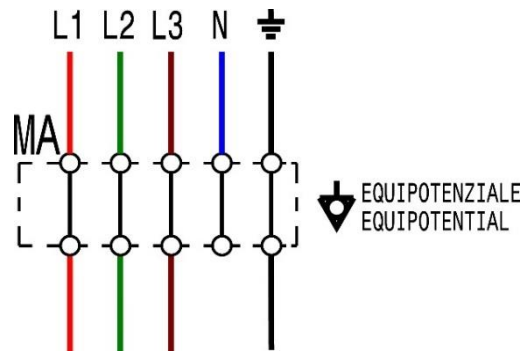

## 2.3.2 RESIDUAL CURRENT

The contact opening max. distance and leakage current must comply with the local safety regulations. Many countries use a 30mA, but you must refer to the local regulations!!



# LIBERO LINE WOK INDUCTION

## 2.4 FIRST START UP

Once that all the supplies connections have been carried out it's time to start up the appliance. Remove the entire protective film from all the paneling's and door; the protective film can be easily removed when the appliance has not been heated up. If the appliance is run for a long period without removing the protective film the film could melt and then be difficult to remove / damage the paneling's finishing.

### 2.4.1 DAILY STARTUP

Please refer to the user manual ; the document is available for authorized technicians on the web sites (PRIDE-SERVICE PORTAL- AGELUX etc..) In case of any doubt, refer to your local country customer care.

Before you turn on the appliance make sure that:

The mains voltage and frequency match those indicated on the appliance data plate at § DATA PLATE (IDENTIFICATION STICKER). Visual check if the supply cable is in good condition.

## 2.5 COMMISSIONING

Please refer to the Commissioning form; the document is available for authorized technicians on the web sites (PRIDE-SERVICE PORTAL- AGELUX etc..) In case of any doubt, refer to your local country customer care.

# LIBERO LINE WOK INDUCTION

## 3 USE OF APPLIANCE

### 3.1 OPERATING INSTRUCTIONS

Please refer to the Installation and Operating Manual of the appliance; the document is available for authorized technicians on the web sites (PRIDE-SERVICE PORTAL- AGELUX etc..) In case of any doubt, refer to your local country customer care.

To use the appliance, press the On / Off button appliance will lamp test and go into "idle"

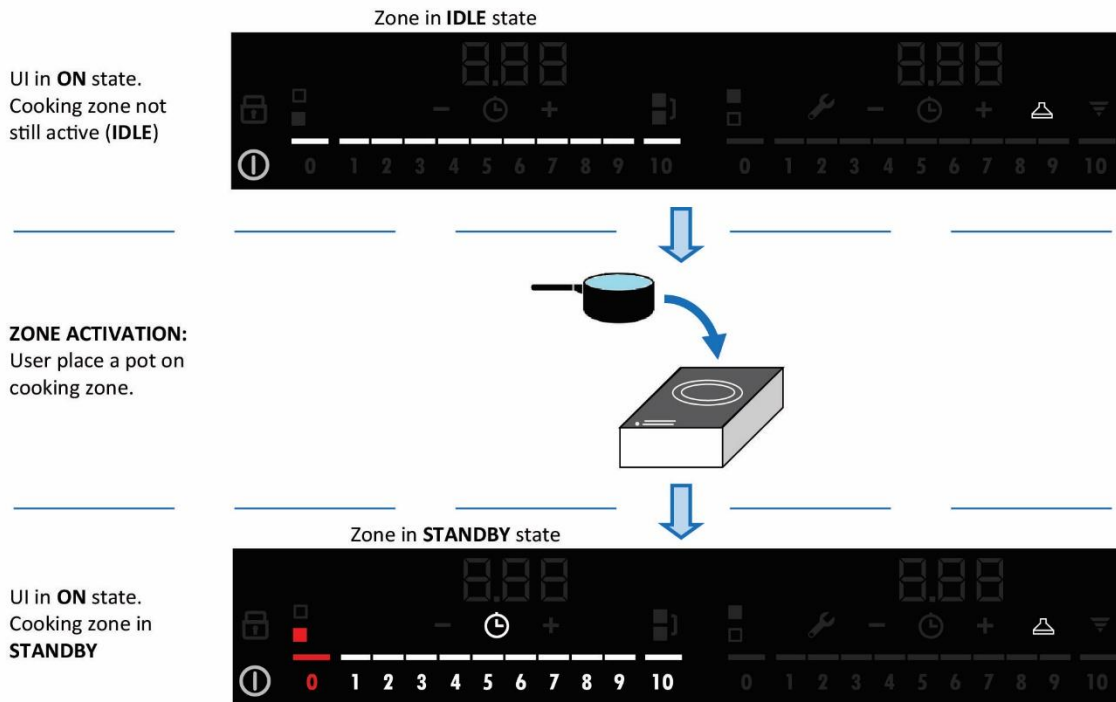

Then deactivate a zone:

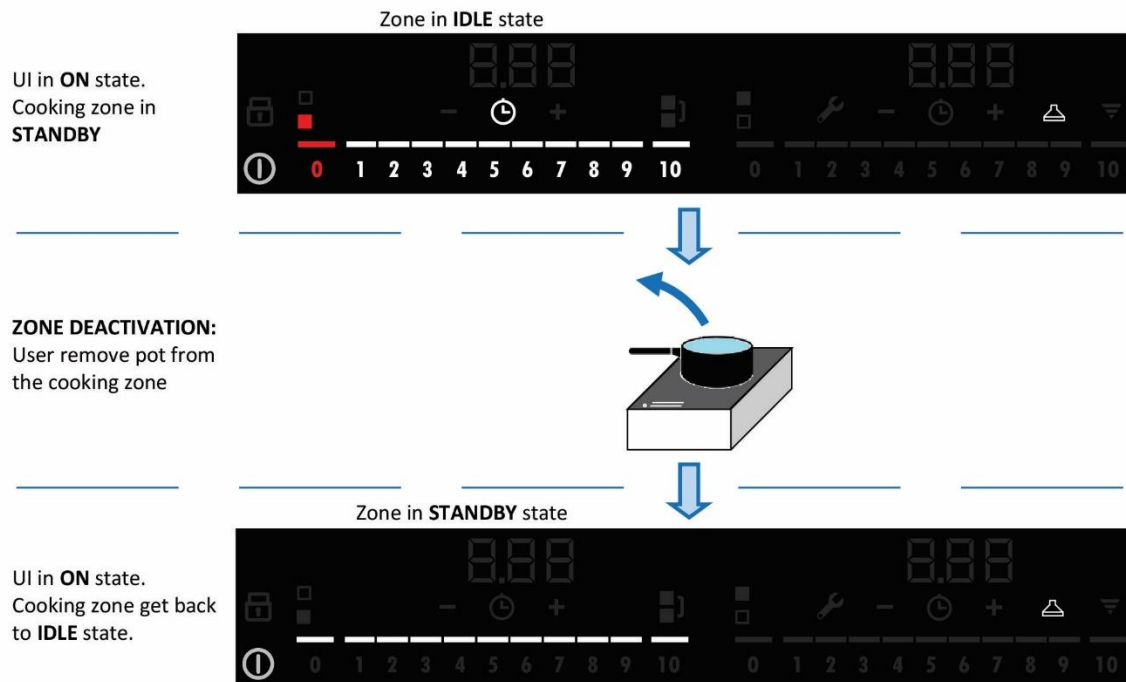

# LIBERO LINE WOK INDUCTION

## 3.2 CLEANING

Turn off the appliance after service and let the appliance cool down.



### CAUTION!

All operations must be carried out following indications at § PERSONAL PROTECTION EQUIPMENT and/or referring to the safety data sheet of products involved during this phase.

### 3.2.1 APPLIANCE & GLASS TOP SURFACE

**Clean the appliance** in presence of encrusted dirt or grease use a damp cloth, do not use abrasive or corrosive detergents as they could damage the surfaces by mechanical aggression (scratches) or chemical aggression (corrosion/stains). Rub the cloth/sponge following the grain of the satin finish and rinse often; rubbing in a circular motion combined with the particles of dirt on the cloth/sponge could damage the steel's satin finish. **Dry** carefully the surfaces after cleaning.

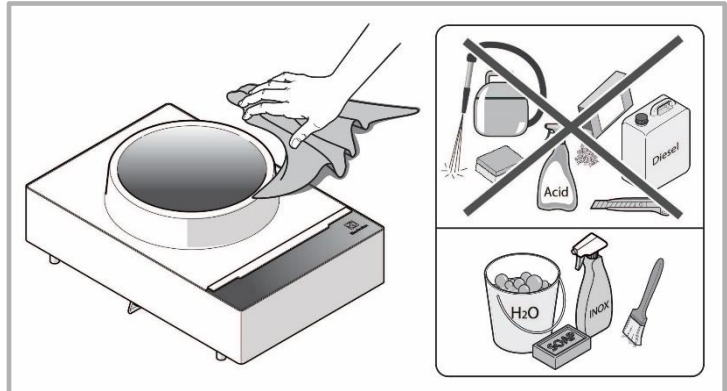

### 3.2.2 AIR FILTERS

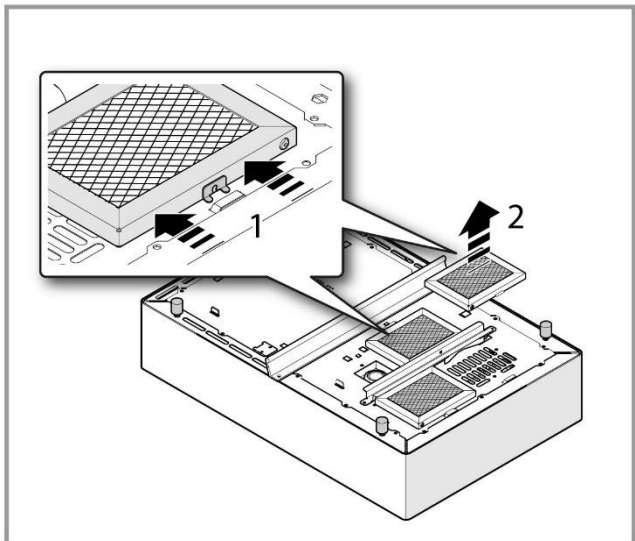
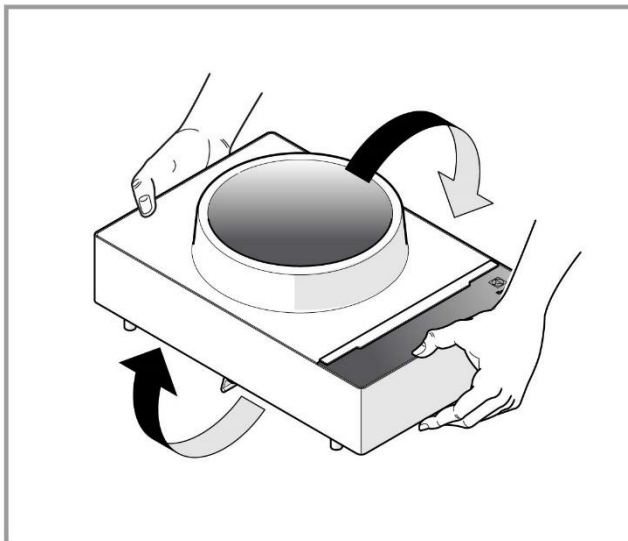

**The air filters:** can be washed separately or inserted into a dish washing machine, dry carefully or leave to dry on a dish rack or towel.

The air filters need to be cleaned when dirty, it's not necessary to clean them after every service .

# LIBERO LINE WOK INDUCTION

## 4 DETAILED APPLIANCE AND COMPONENTS DESCRIPTION/FUNCTIONING

The following chapters are intended only for authorized technicians / engineers



### WARNING !

Take GREAT CARE when connecting / testing anything with live current, if you are unsure what you are doing and how to use your equipment safely, then **DON'T DO IT.**

### 4.1 FUNCTIONAL / TECHNICAL DESCRIPTION

### 4.2 EQUIPMENT FUNCTIONING

In an induction Hob normally, the coils will heat up the pots if they are detected on the cooking top; with the induction griddle the detection is not necessary because the coils heat up the griddle cooking surface.

When turned ON and temperature regulated the coils under the griddle cooking surface bond with the top and start to work immediately.

### 4.3 AIR CIRCULATION

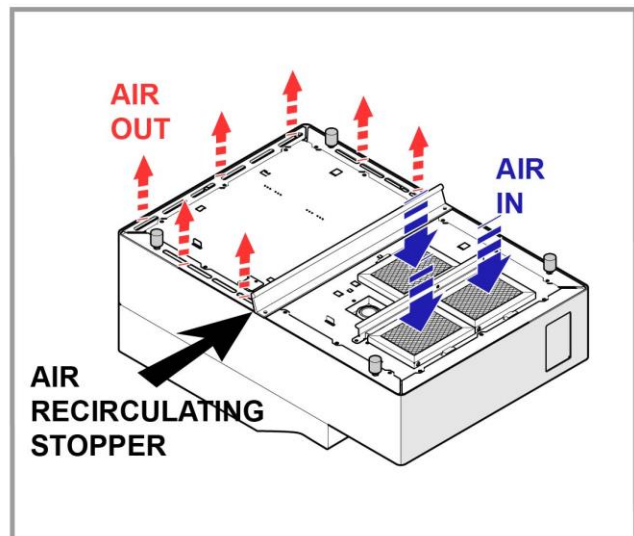
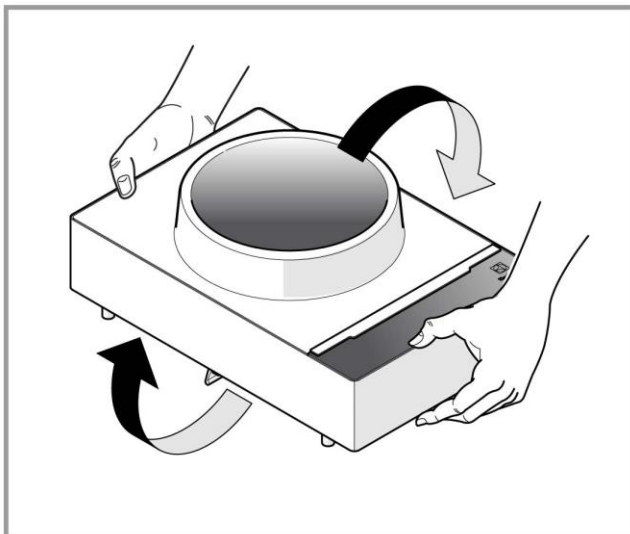

The appliance is a high performer and will require a big amount of fresh air to cool its internal components.

In case that the air filters do not get cleaned when dirty the appliance could overheat and an alarm will be shown on the display.



### NOTE !

If the filters start to get dirty and limit the fresh air passage, before emitting an “over heating alarm” the appliance will start to limit the energy emission of the POW, a typical call from a customer could be “ the appliance is not performing any more” or “ after some time the appliance is not performing”. first check is making the customer have a look at the air intake filters and in case they are dirty, dismount, wash and reinstall.

# LIBERO LINE WOK INDUCTION

## 4.4 COMPONENTS, DESCRIPTION/FUNCTIONING, APPLIANCE 3500W

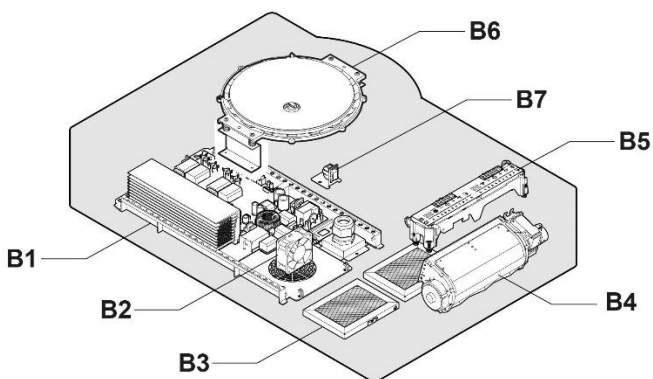

Pos.	Component	§.
B1	Generator POB, TESLA	<u>GENERATOR</u>
B2	Ventilator	<u>VENTILATOR</u>
B3	AIR Filters	<u>FILTER</u>
B4	Ventilator tang M1	<u>VENTILATOR (TANGENTIAL)</u>
B5	User board	<u>USER INTERFACE, U.I</u>
B6	Coils & temperature sensors	<u>COIL</u>

### 4.4.1 GENERATOR TESLA, POW

The "Tesla" generator is used on the 1ph appliances.

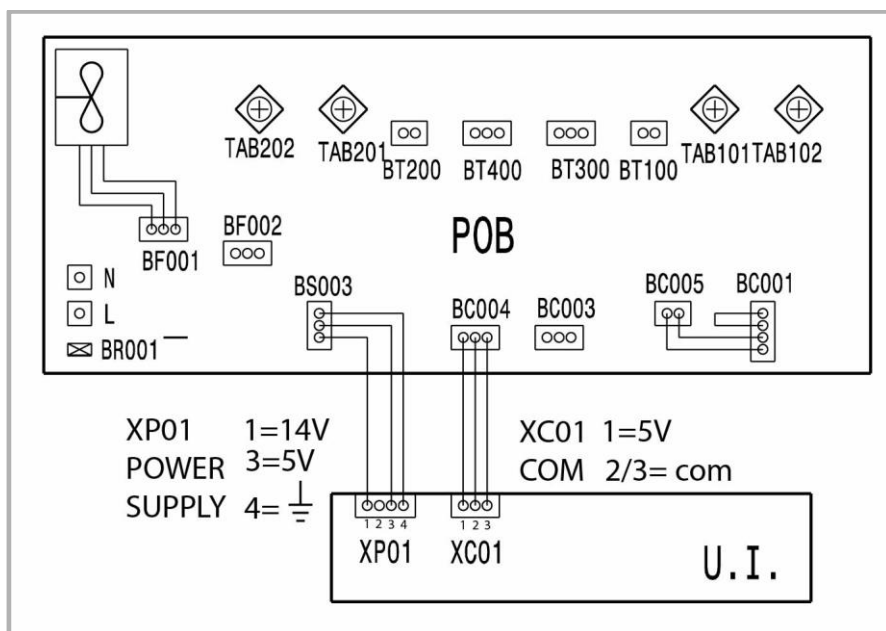

# LIBERO LINE WOK INDUCTION

## 4.4.2 VENTILATOR

The ventilator BF001 is included into the Generator assembly, it is not available as a single spare part.

The ventilator is commanded directly by the Generator; its purpose is to cool down the heat dispel finned pack, it's a 12v supplied motor.

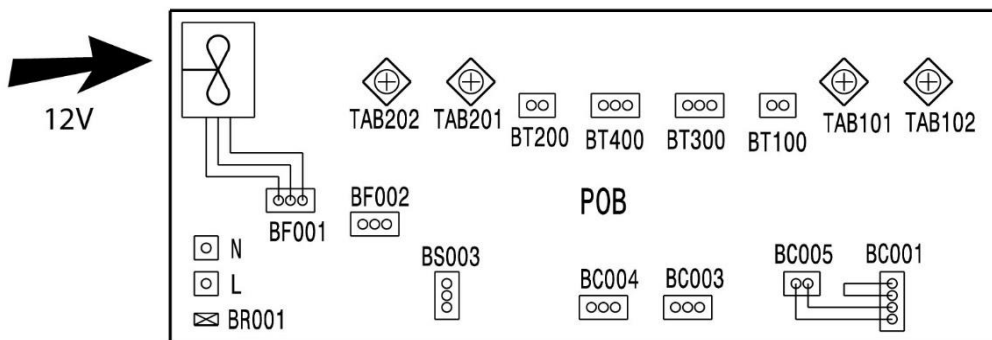
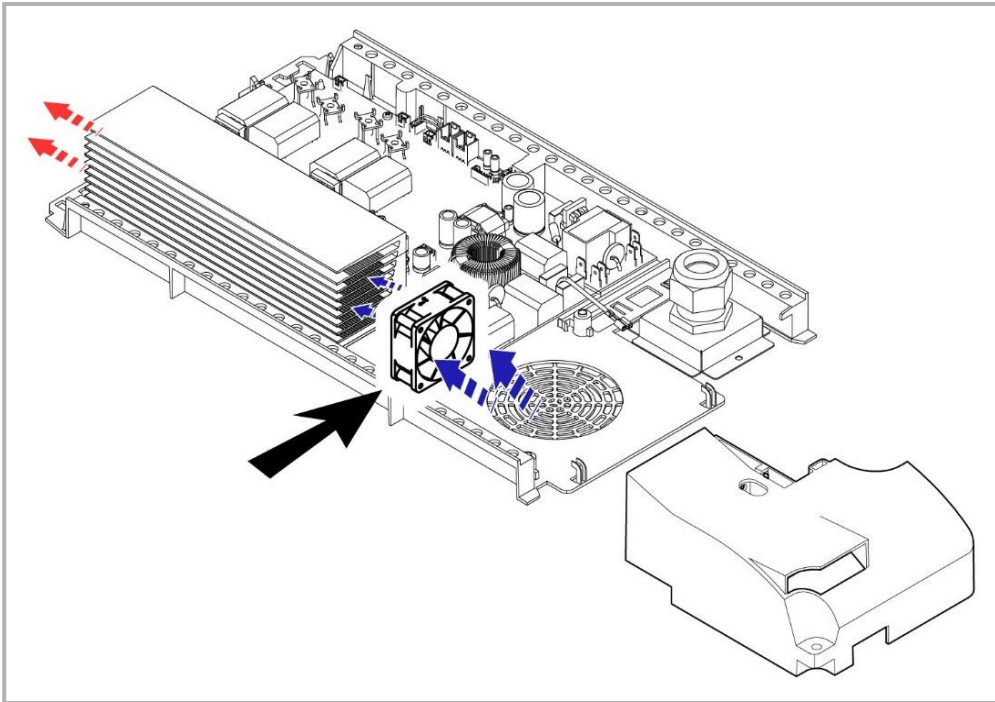

# LIBERO LINE WOK INDUCTION

## 4.4.3 AIR FILTER

The air filters can be washed separately or inserted into a dish washing machine, dry carefully or leave to dry on a dish rack or towel. In case of clogging up the appliance can over heat and generate an alarm

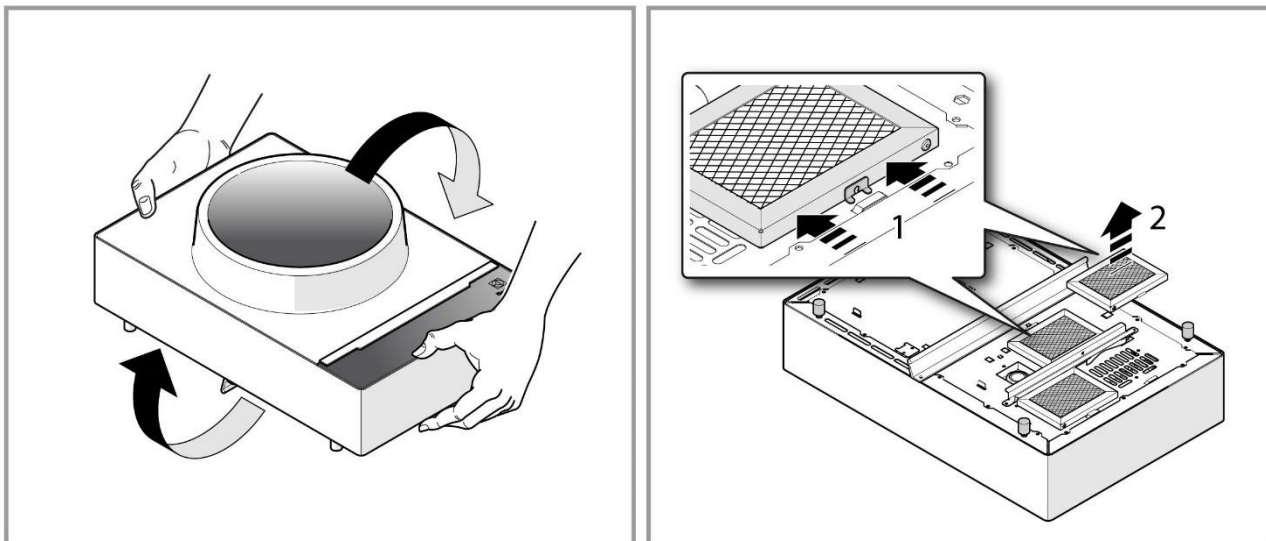

### NOTE !

If the filters start to get dirty and limit the fresh air passage, before emitting an “over heating alarm” the appliance will start to limit the energy emission of the POW, a typical call from a customer could be “ the appliance is not performing any more” or “ after some time the appliance is not performing”. first phone check is making the customer have a look at the air intake filters and in case of need dismount them, wash and reinstall.

## 4.4.4 VENTILATOR (TANGENTIAL) M1

BF002 is the tachometer signal cable.

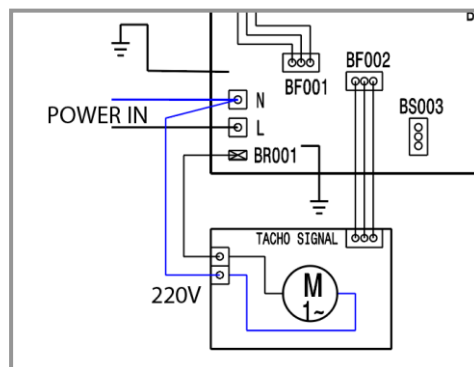
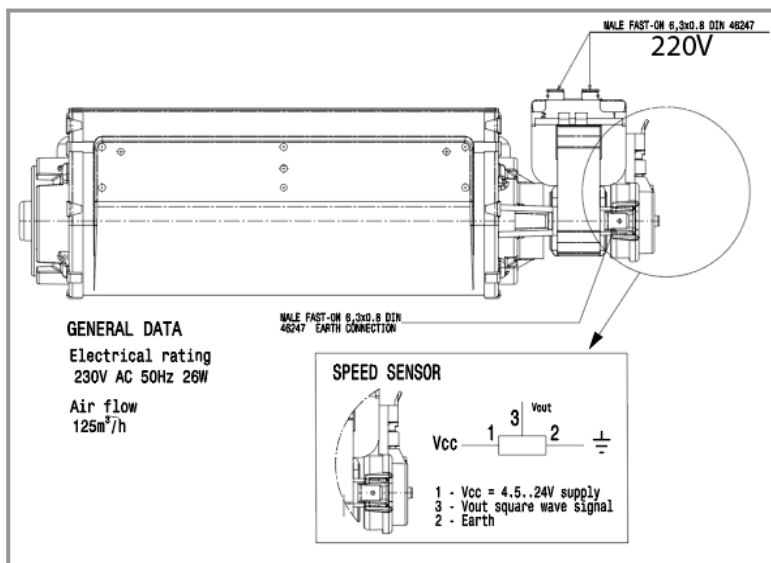

# LIBERO LINE WOK INDUCTION

## 4.4.5 USER INTERFACE, U.I

XP01 is the power supply connector / XC01 is the communication cable (U.I to Generator).

To give power supply to the U.I only one POW(pob) needs to have the bridge cable from BC001 to BC005. The POW that will not have connected a U.I does NOT need this small bridge cable, or the POW will go in short!! Refer also to the EWD at [ELECTRIC WIRING DIAGRAM \(EXAMPLE\)](#)

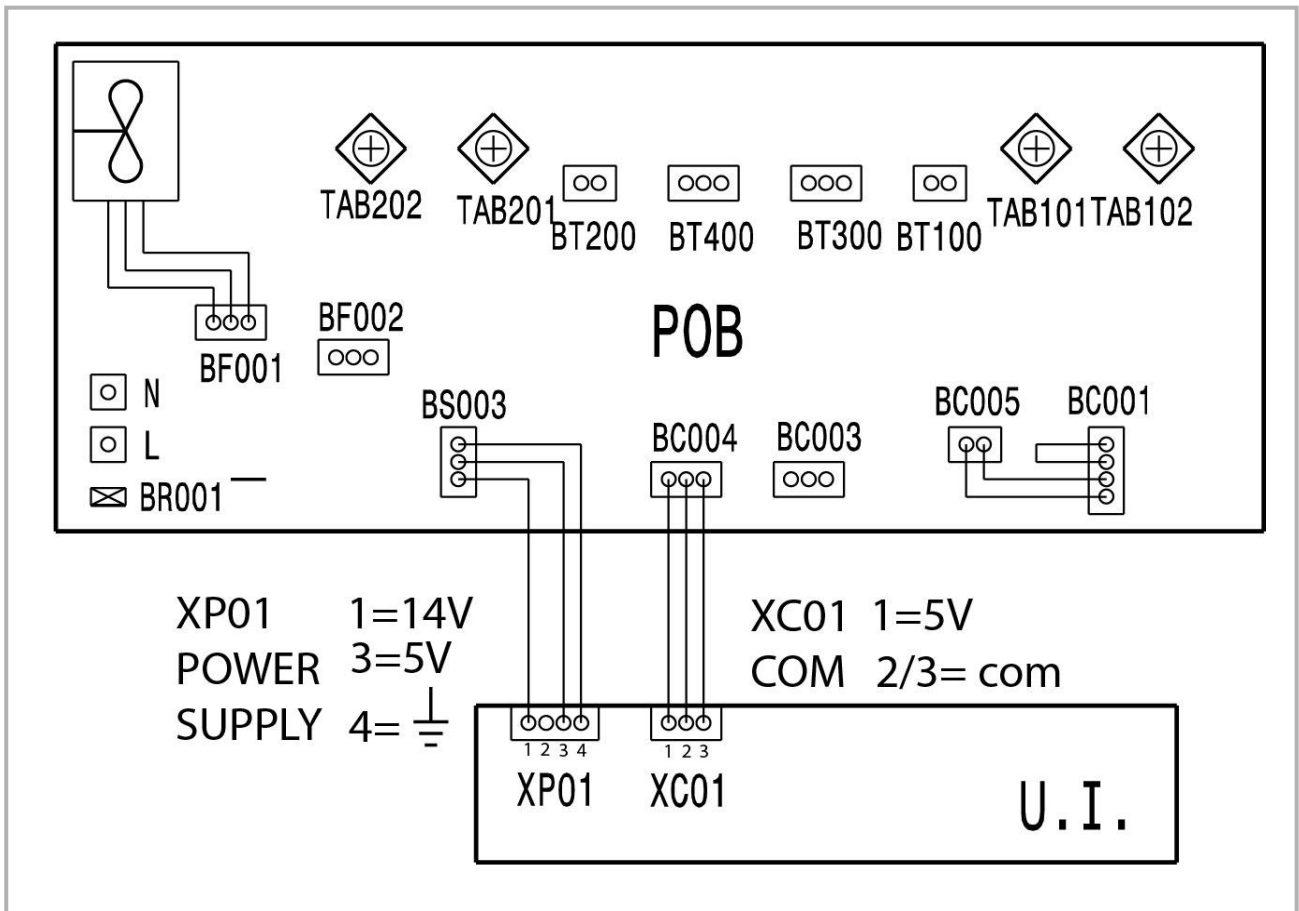



# LIBERO LINE WOK INDUCTION

## 4.4.6 COILS & TEMPERATURE SENSORS,

**WOK** appliances have a coil  $\varnothing$  210mm with a single winding. The temperature sensor is part of the coil and cannot be replaced..

At the center of each coil is located the temperature probe that acts also as safety probe.

- temperature sensor, if the temperature is spiking over set point of max temperature (212°) the safety sensor will slowly cut down the power of the generator, if the temperature of the surface does not go down and it reaches 222C° the sensor will input to shut down the Generator.

There is no manual resetting of the safety sensor, this because it is electronically controlled; once that the appliance has cooled down (the appliance will keep in function the ventilation system in case of safety temp. activation) the appliance will turn back on and restart functioning.

In case of overheating an alarm will be displayed on the U.I. § [ALARM CODE LIST](#)

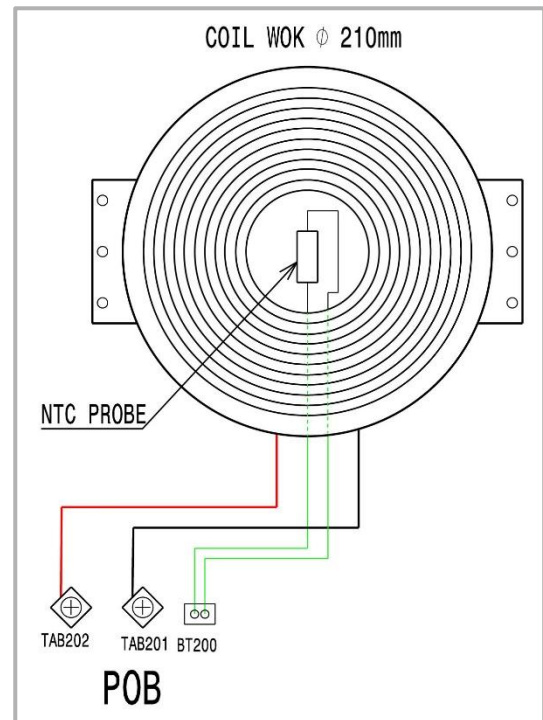

# LIBERO LINE WOK INDUCTION

## 4.5 COMPONENTS, DESCRIPTION/FUNCTIONING, APPLIANCE 5000W

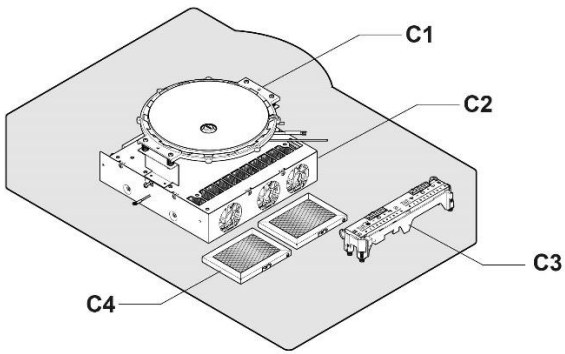

Pos .	Component	\$.
C1 + C2	Coils & temperature sensors Generator POW, FOUCAULT Filter	<u>GENERATOR</u> <u>FOUCAULT</u>
C3	User board U.I	<u>USER</u> <u>BOARD, U.I</u>

### 4.5.1 GENERATOR FOUCAULT - COILS & TEMPERATURE SENSOR

The "FOUCAULT" generator is used on the 3ph appliances. All generators can be identified with a specific factory code indicated in a dedicated sticker placed on the side of the generator

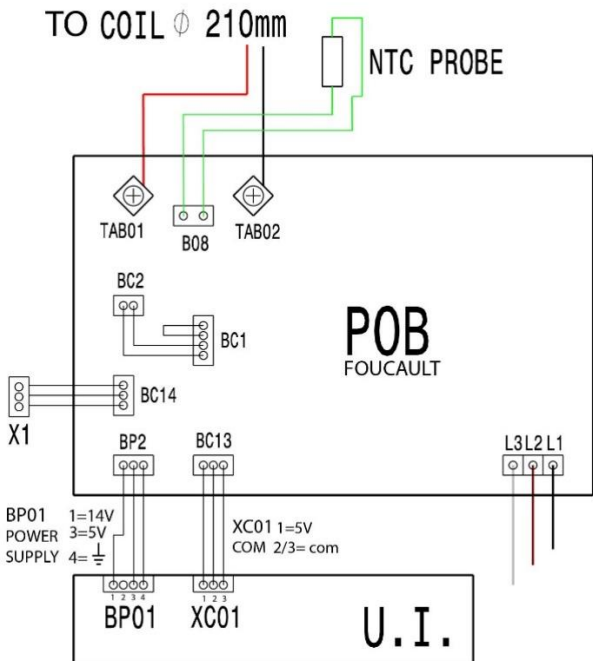
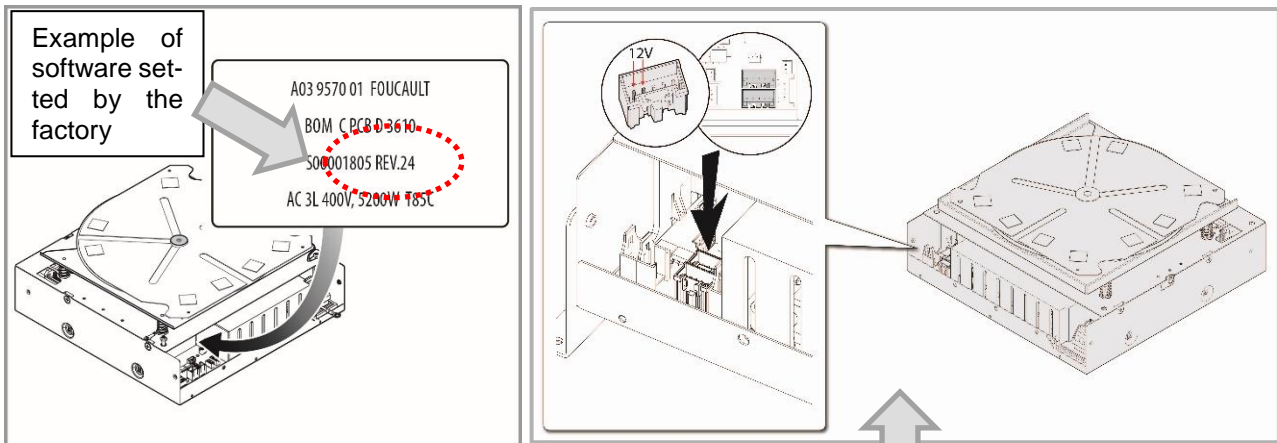

To check if the inner voltage adaptor is functioning . The voltage adaptor is a component located inside the generator and cannot be replaced, but It can be checked. Locate the connectors , check the indicated pins; If there is no voltage (12v) on these pins the inner voltage adaptor is broke.

# LIBERO LINE WOK INDUCTION



## NOTE !

the temperature probe and coil are part of the generator assembly and not available as single spare parts.

**The temperature sensor** is located at the center of the coil; if the temperature is spiking over set point of max temperature (260°) the safety sensor will slowly cut down the power of the generator, if the temperature of the surface does not go down and it reaches 280C° the sensor will input to shut down the Generator.

There is no manual resetting of the temperature sensor, this because it is electronically controlled; once that the appliance has cooled down (the appliance will keep in function the ventilation system in case of safety temp. activation) the appliance will turn back on and restart functioning.

In case of overheating an alarm will be displayed on the U.I. § [ALARM CODE LIST](#)

## 4.5.2 USER BOARD, U.I

BP01 is the power supply connector / XC01 is the communication cable (U.I to Generator).

Refer also to the EWD at [ELECTRIC WIRING DIAGRAM \(EXAMPLE\)](#)

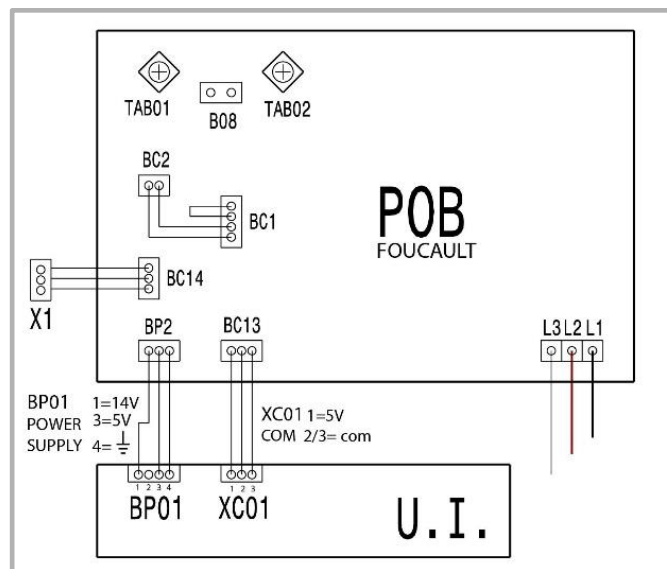

## 4.6 INDUCTION POTS, PRECAUTIONS

All wok pans must be designed to be used on induction appliances; generally, all are branded with the indicated logo on the bottom.



Use pans with rounded bottom in iron, iron plate, enameled iron, cast iron, special multilayer metal.

Do not use pots in layered metal with aluminum body and open edge.

The heating system will not work with unsuitable materials; these are: nickel chromium, S/steel, aluminum, copper, brass, glass, porcelain.

To avoid compromising inductor functionality, never use pots with bottoms that are not perfectly flat: the temperature may not be measured correctly, this because the temperature sensor is at the center of the coil and it needs to "sens" the pans temperature and be in contact with it.

Do not use empty pots or pans on the appliance as they can quickly (in a few seconds) reach very high temperatures.



# LIBERO LINE WOK INDUCTION

## 4.7 PERFORMANCE

Not all pans have the same performance; some pans will have the induction logo  but will not perform / respond in a good manner.

A quick way to check if the pan is suitable for induction is to use a magnet: if it will stick to the bottom of the pan (part in contact with the induction top) this means the pan will probably work on induction appliance otherwise it will not.

In the picture 1 is an example of the power absorbed by a «bad» pan and a «good performing» pan; both pans are suitable for induction appliances, but one pan is responding better.

To check the «performance» of pans there are TWO methods:

- **checking the power absorbed** (AMPS) on each generator with a current clamp, regulate the zone at full power measure and swap pans on the same zone!; remember that there are different editions of generators with different power output levels (refer to the § POWER TABLE ) if you compare different zones.

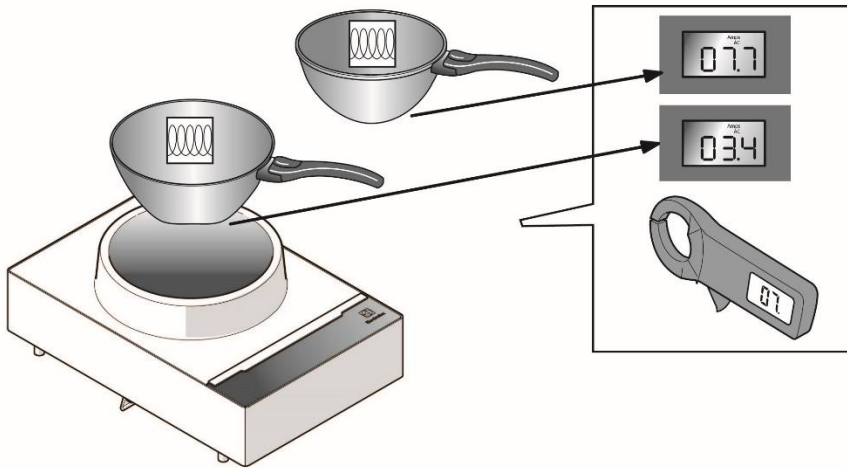

- use the **automatic HOB** function, explained at § S4, COOKING TOP COUPLING

# LIBERO LINE WOK INDUCTION

## 4.7.1 POWER TABLE 1PH-WOK

Single Phase WOK

POWER TABLE [1PH-SZ-WOK]		
Power level	Power table [W] - Zone 1 - (UI Left / POB Rear)	Power table [W] - Zone 2 - Not used
0	0	0
1	152	0
2	520	0
3	900	0
4	1272	0
5	1640	0
6	2012	0
7	2380	0
8	2752	0
9	3132	0
10	3500	0

Appliance max power: 3700W

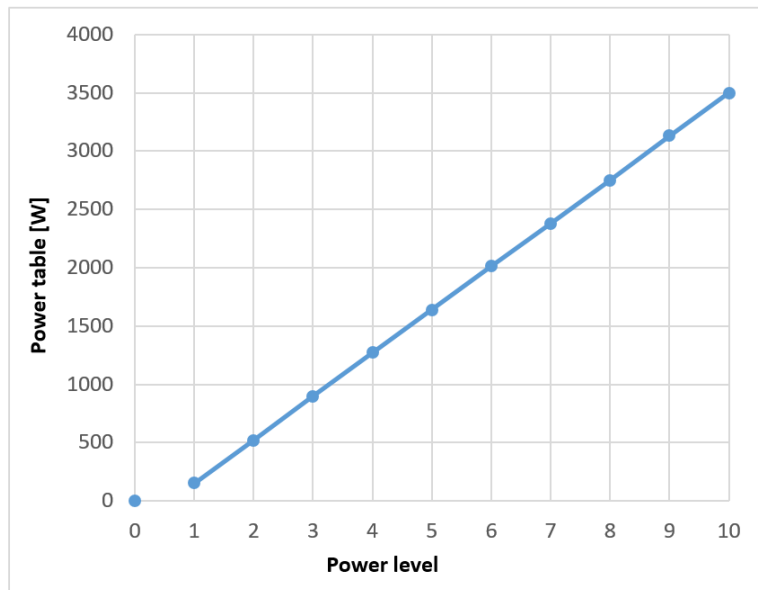

## 4.7.2 POWER TABLE 3PH-WOK

3-phase WOK

POWER TABLE [3PH-SZ-WOK]		
Power level	Power table [W] - Zone 1 - (UI Left / POB Rear)	Power table [W] - Zone 2 - Not used
0	0	0
1	152	0
2	272	0
3	452	0
4	660	0
5	900	0
6	1252	0
7	1800	0
8	2500	0
9	3552	0
10	5200	0

Appliance max power: 5400W

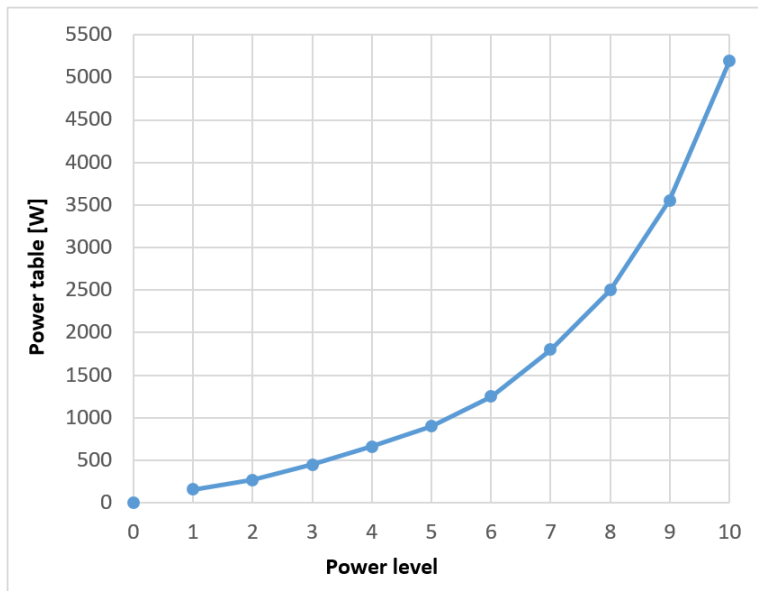

# LIBERO LINE WOK INDUCTION

## 4.8 ELECTRONIC BOARD

### 4.8.1 SWITCHING ON / OFF

Turn **ON** the appliance by pressing the On/Off button for 3 seconds.

Once in **ON** state, there are different possibilities to return to **OFF** state again:

**Manual Switch OFF**, operating on the On/Off button. This possibility is always available, no matter if cooking zones are cooking or not.

**Automatic Switch OFF**, when all cooking zones are not cooking, and the UI does not sense any user activity on the appliance for a proper timeout.

**Safety Switch OFF**, when the UI sense a permanent pressure on at least one active button or slider point.



#### NOTE !

When turning off in case of residual heat inside the cooking surface on the display will be visualized

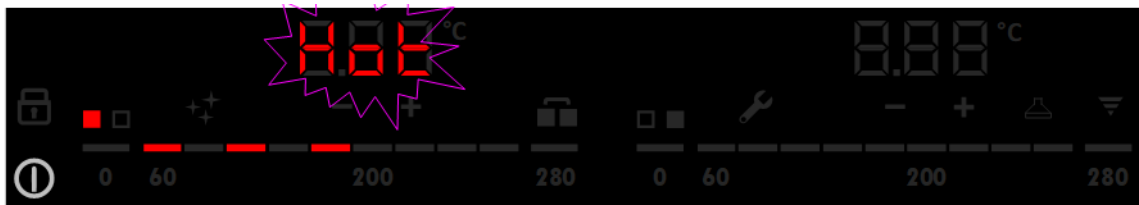

# LIBERO LINE WOK INDUCTION

## 4.8.2 CUSTOMER MENU

Accessing the customer Menu allows you to:

-Set the Buzzer mode.

-Set the Hob2Hood mode.

-Show the alarm history. Up to 5 alarm codes are showed, starting from the newest one to the oldest one.

The Customer Menu is only available starting from **OFF** or **COOLING\_DOWN** state. When exiting the menu, the UI return to **OFF** or **COOLING\_DOWN** state, to access:

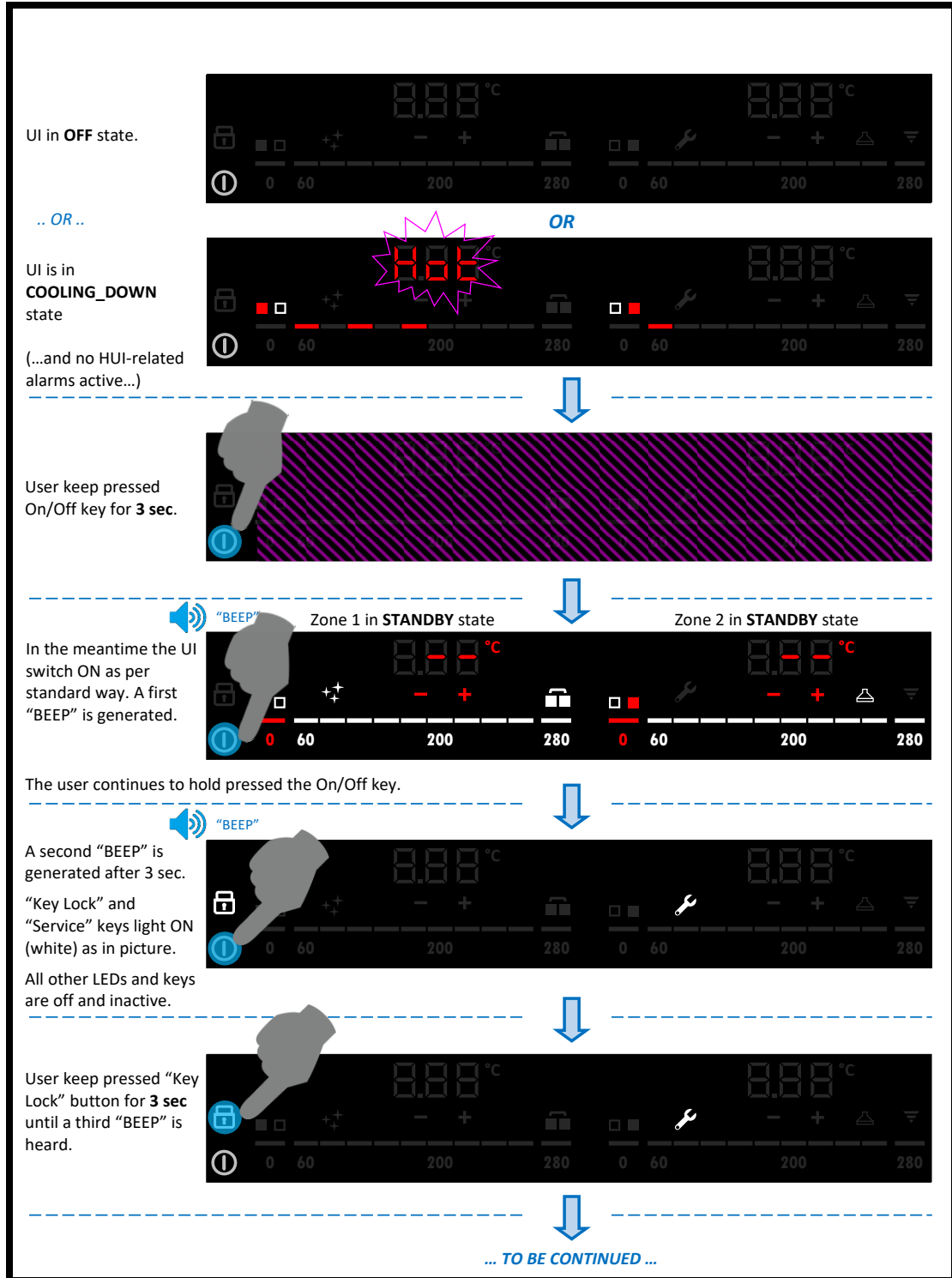

# LIBERO LINE WOK INDUCTION

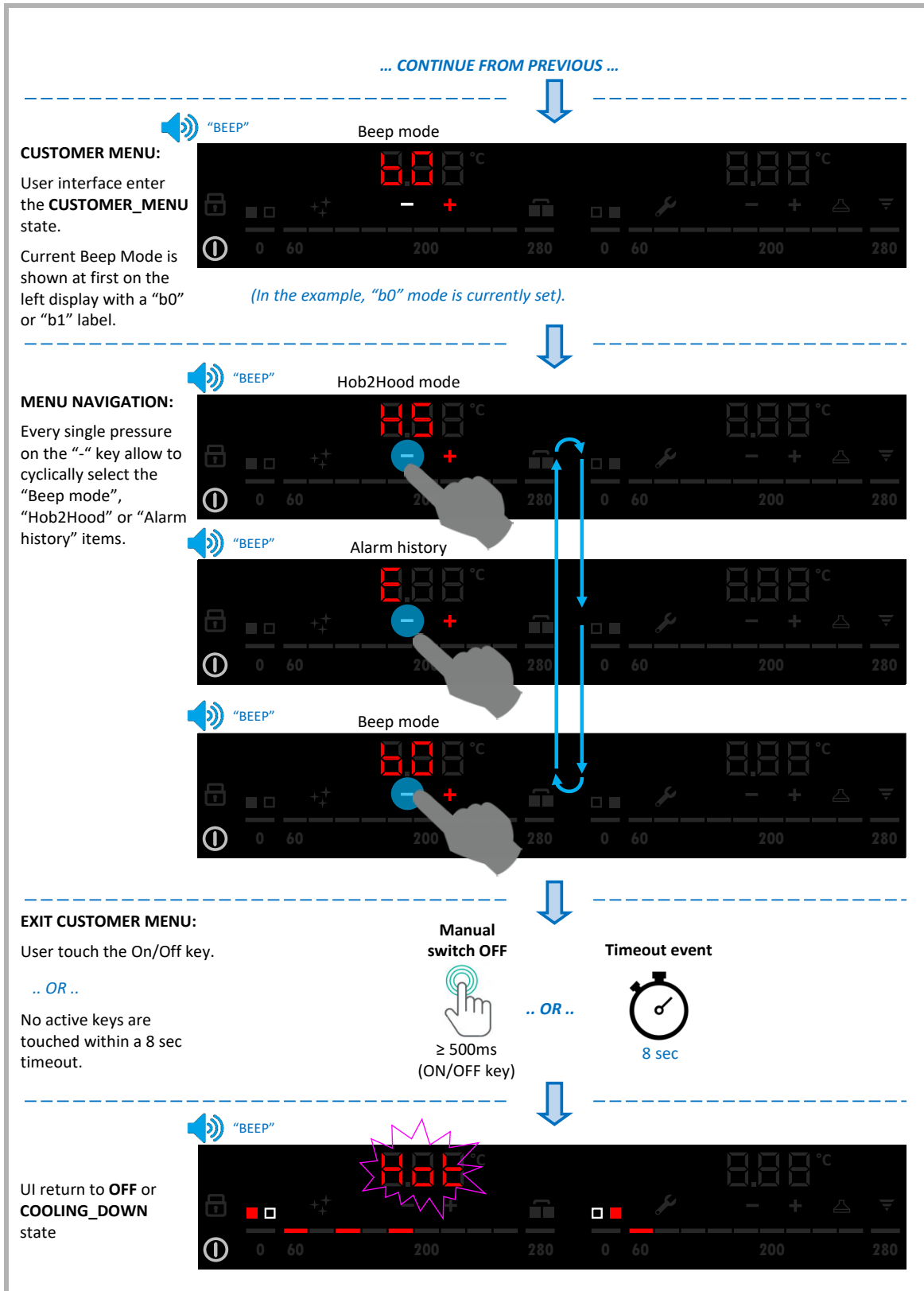



# LIBERO LINE WOK INDUCTION

## 4.8.2.1 BUZZER MODE

Set the Buzzer mode. Available modes are “b0” and “b1”.

- b0 : Full buzzer use as described in this document;
  - b1: Reduced buzzer use. Buzzer is normally disabled except:
    - Switch ON
    - Switch OFF, no matter if manual or automatic
    - Safety switch OFF routine with 5 “BEEP” sequence
    - Temperature Set Point reached (Preheating / Pre-cooling animation stop);
    - Cleaning end
- All operations inside CUSTOMER MENU, including menu access sequence;  
All operations inside SERVICE MENU, including menu access sequence.

The user enter the CUSTOMER  
*(Example only, current Beep mode maybe “b0” or “b1”)*

Beep mode = b0: Full buzzer use *(Example only)*

“BEEP” Beep mode = b1: Reduced buzzer use

**SET BEEP MODE:**  
Every single pressure on the “+” key cyclically change the Beep mode.

“BEEP” Beep mode = b0: Full buzzer use

Once selected the desired Beep mode, user can press “-” key to switch to “Hob2Hood” setting page, press On/Off key to exit CUSTOMER MENU or wait 8 sec to automatically exit from CUSTOMER MENU .

**Exiting the Beep Mode page the new mode is stored.** In case of power failure the setting is unchanged.

# LIBERO LINE WOK INDUCTION

## 4.8.2.2 HOB2HOOD MODE

The user enter the CUSTOMER MENU and select the Hob2Hood item.

*(Example only, current Hob2Hood mode maybe from H0 to H6)*

### SET HOB2HOOD MODE:

Every single pressure on the "+" key increase the set.

Note: every single pressure on the key indicated with the dashed circle decrease the set.

Selection is repeated cyclically from H0 to H6.

Once selected the desired value, user can press "-" key to switch to Alarm history, press On/Off key to exit CUSTOMER MENU or wait 8 sec to automatically exit from CUSTOMER MENU .

**Exiting the Hob2Hood page the new set is stored.** In case of power failure the setting is unchanged.

Hob2Hood mode = H5 (Example only)

"BEEP" Hob2Hood mode = H6

"BEEP" Hob2Hood mode = H0

"BEEP" Hob2Hood mode = H1

"BEEP" Hob2Hood mode = H2

"BEEP" Hob2Hood mode = H3

"BEEP" Hob2Hood mode = H4

"BEEP" Hob2Hood mode = H5

# LIBERO LINE WOK INDUCTION

## 4.8.2.3 ALARM HISTORY

The user enter the CUSTOMER MENU and select the Alarm History item .

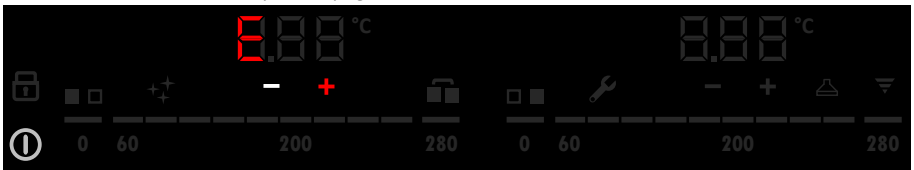

Alarm History initial page

VIEW ALARM HISTORY:  
User touch the "+" key to view the alarm history.

"BEEP"

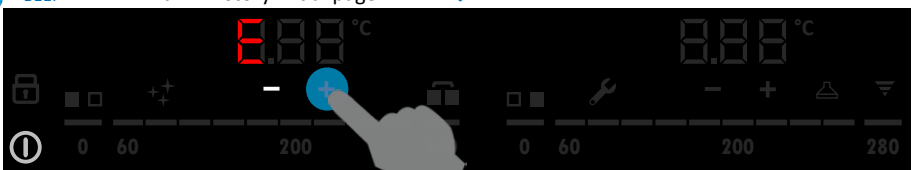

Alarm History initial page

(Example for E821)

Step 1 Zone 1 Zone 2

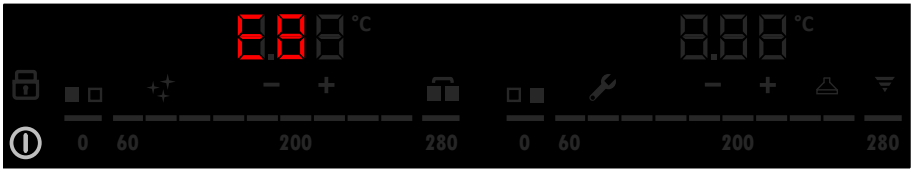

Step 2



Step 3

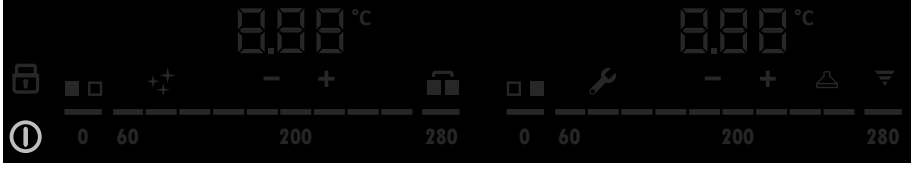

5 x (5 sec)

The last 5 stored alarm codes are displayed, starting with the **newest** occurred to the **oldest** one.  
Every alarm code is displayed for 5 seconds (2 times) following the standard visualization scheme .  
Alarm codes appears in the same position where they originally appeared in ON state, meaning on one display only or replicated on both .

**NOTE: The sequence is always executed 5 times. If less than 5 alarm codes are stored then the UI is completely off for void positions until the final timeout is reached.**

"BEEP"

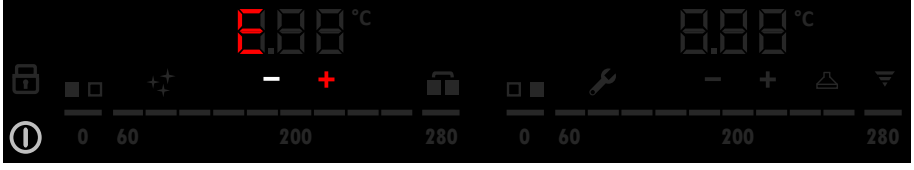

Alarm History initial page

At the end of the sequence the UI automatically return to the Alarm History initial page.

User can press "-" key to switch to "Beep mode" setting page, press "+" key to restart alarm history visualization, press On/Off key to exit CUSTOMER MENU or wait 8 sec to automatically exit from CUSTOMER MENU .

Up to 5 alarm codes are showed, starting from the newest one to the oldest one.

# LIBERO LINE WOK INDUCTION

## 4.8.3 SERVICE MENU

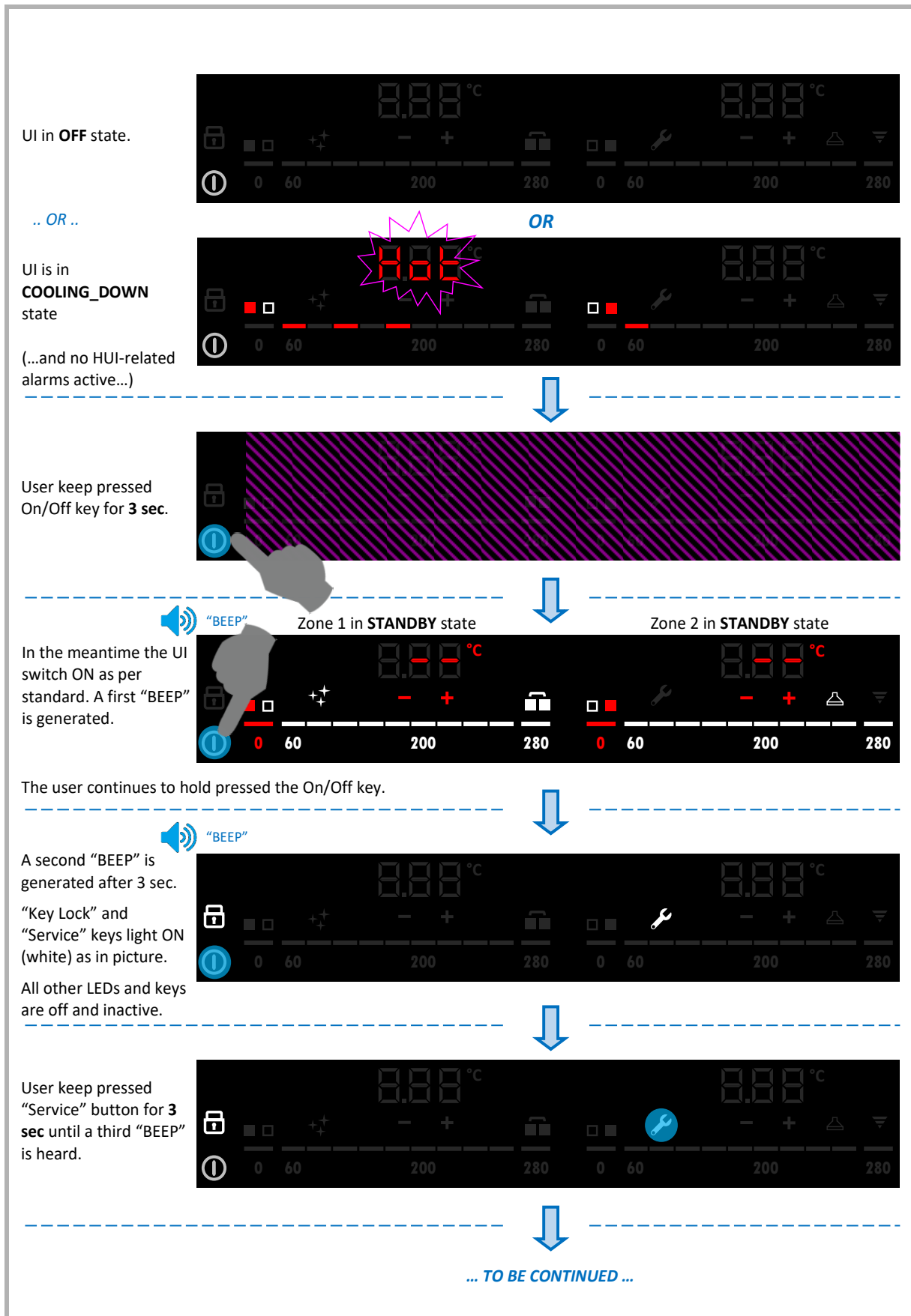

# LIBERO LINE WOK INDUCTION

... CONTINUE FROM PREVIOUS ...

**SERVICE MENU:**  
User interface enter the **SERVICE\_MENU** state.  
Current Demo mode is shown at first on the left display with a "d" or "do" label.

**Demo mode**



(In the example, Demo is disabled).

**MENU NAVIGATION:**  
Every single pressure on the left "-" key allow to cyclically select the available items in the order "Demo mode", "S1", "S2", "S3" and "S4".

**Service utility S1**

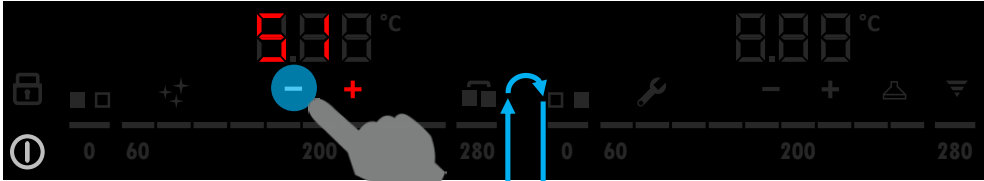

**Service utility S2**

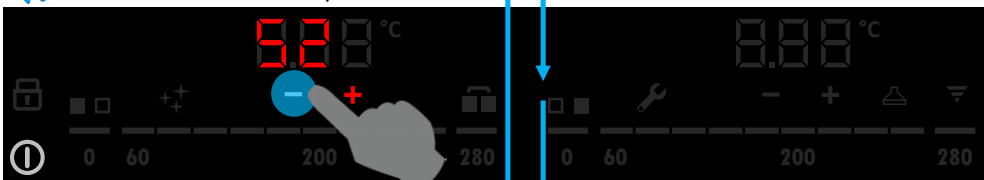

**Service utility S3**

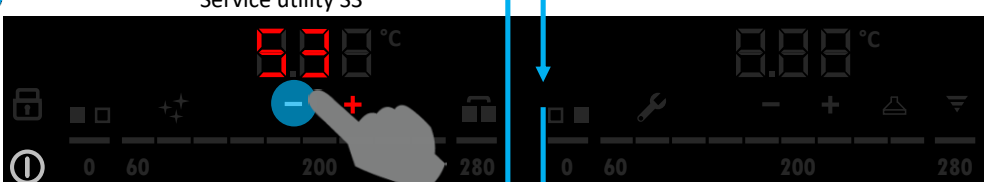

**Service utility S4**

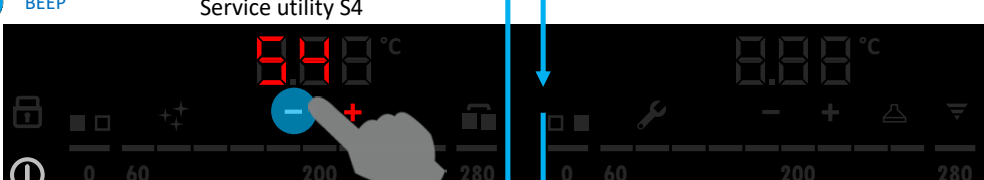

**Demo mode ("d" or "do")**

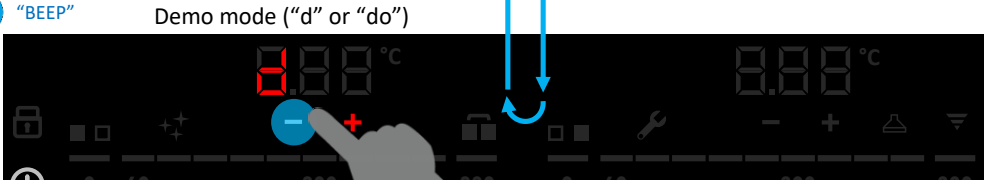

... TO BE CONTINUED ...

# LIBERO LINE WOK INDUCTION

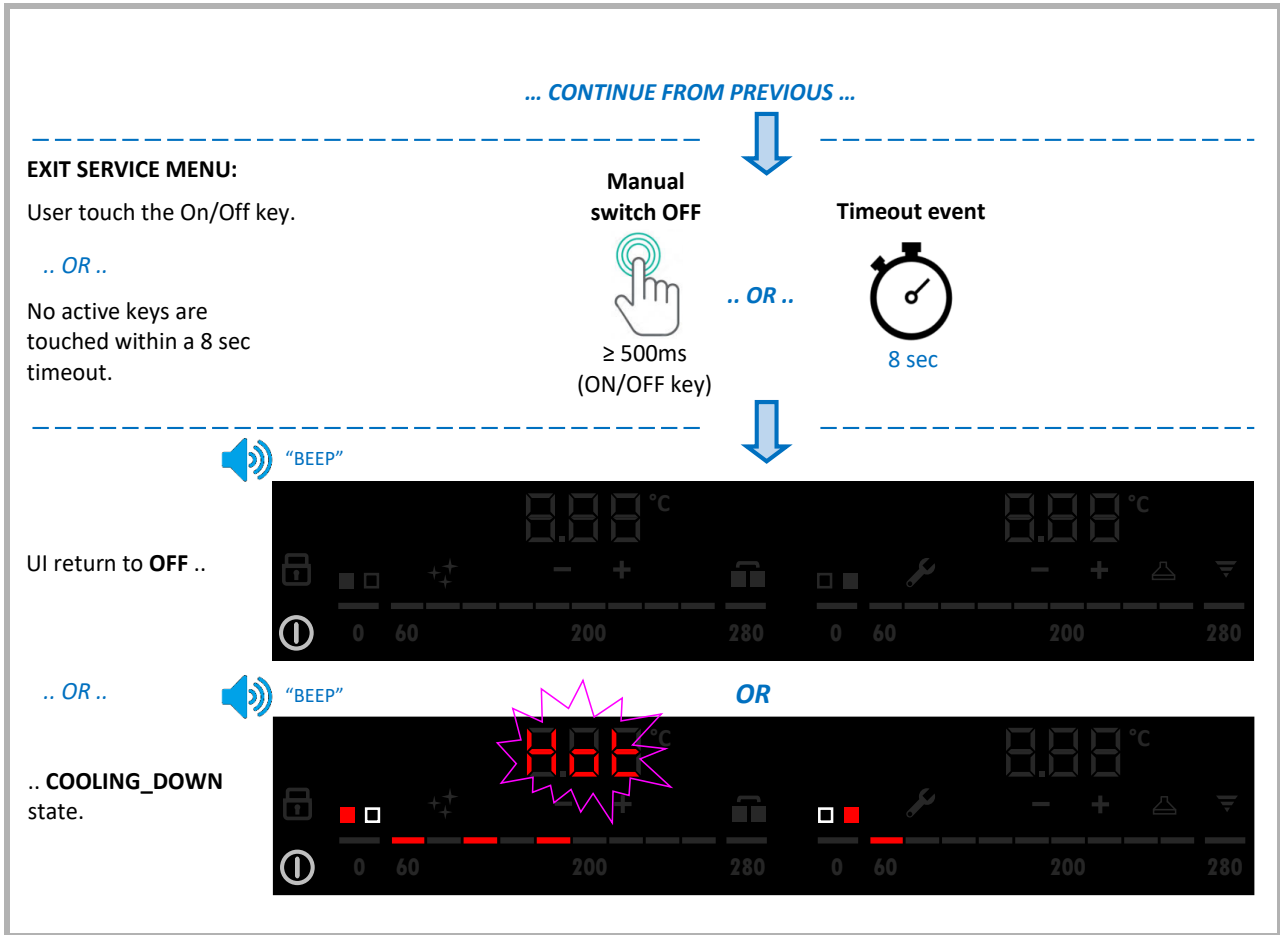

## 4.8.3.1 DEMO MODE

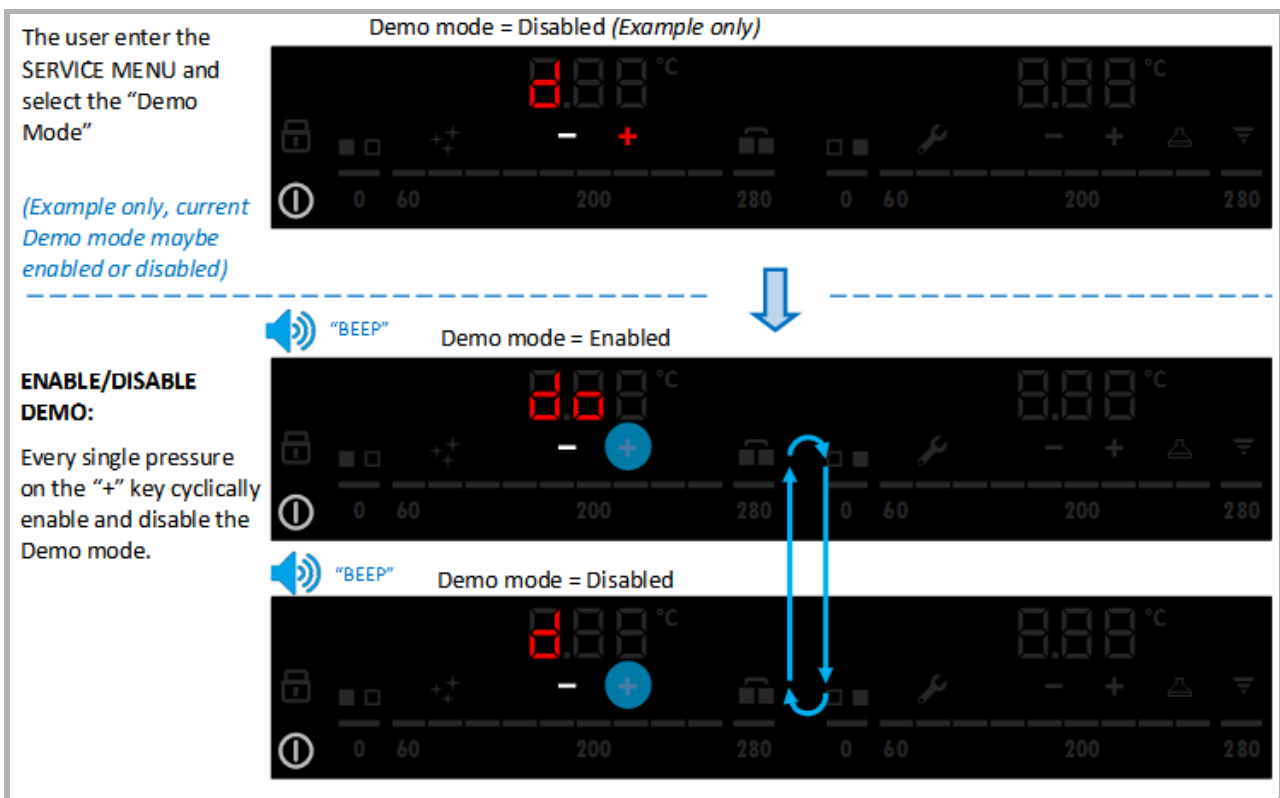

# LIBERO LINE WOK INDUCTION

## 4.8.3.2 SI, SOFTWARE EDITION

This function permits you to resume a "lamp test", like a first power on so you can check the software installed on the appliance.

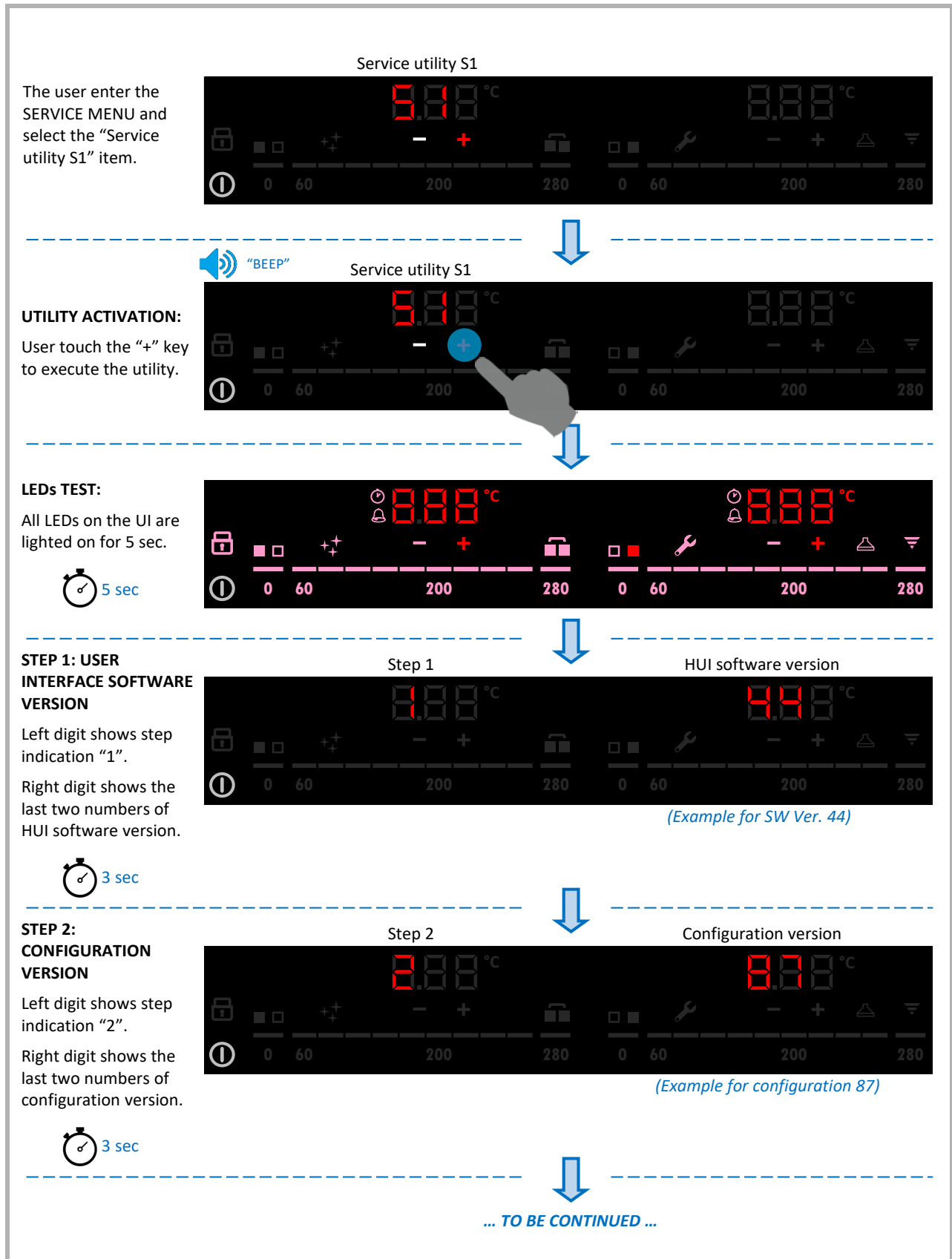

# LIBERO LINE WOK INDUCTION

... CONTINUE FROM PREVIOUS ...

## STEP 3: HC1 POWER BOARD SOFTWARE VERSION

Left digit shows step indication "3".  
Right digit shows the last two numbers of HC1 software version.

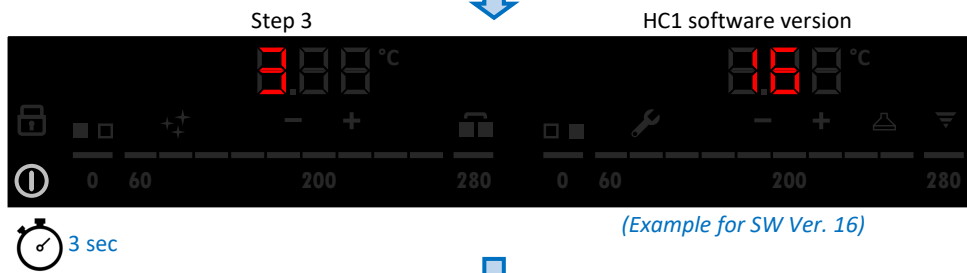

## STEP 4: HC1 POWER BOARD "Power-Micro" VERSION

Tesla HC: Not used (right digit shows "--").  
Foucault HC: Right digit shows the last two numbers of HC1 "Power-Micro" version.

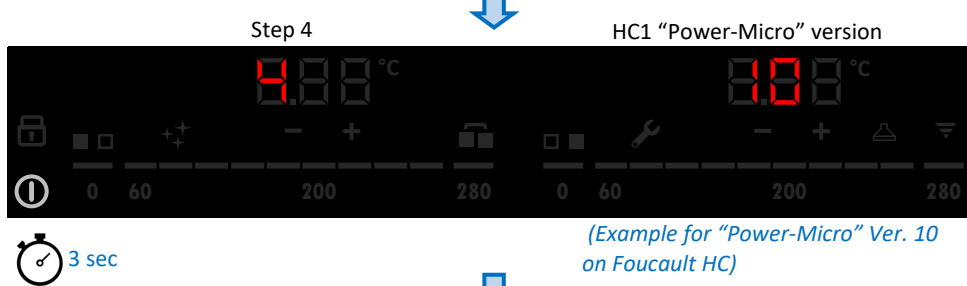

## STEP 5: HC2 POWER BOARD SOFTWARE VERSION

Left digit shows step indication "5".  
Right digit shows the last two numbers of HC2 software version.

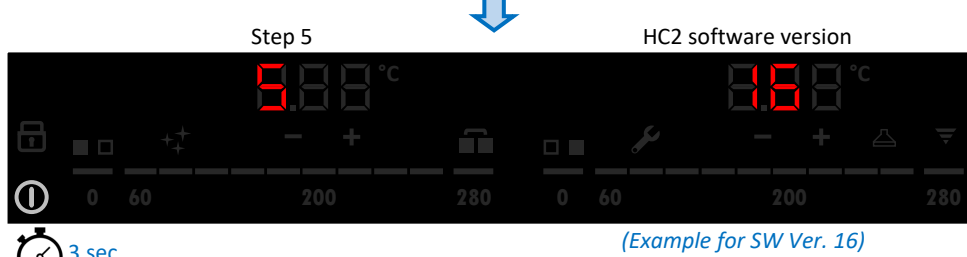

This step is present only for configurations with two power boards, meaning for Double Zone Frytop.

## STEP 6: HC2 POWER BOARD "Power-Micro" VERSION

Tesla HC: Not used (right digit shows "--").  
Foucault HC: Right digit shows the last two numbers of HC2 "Power-Micro" version.

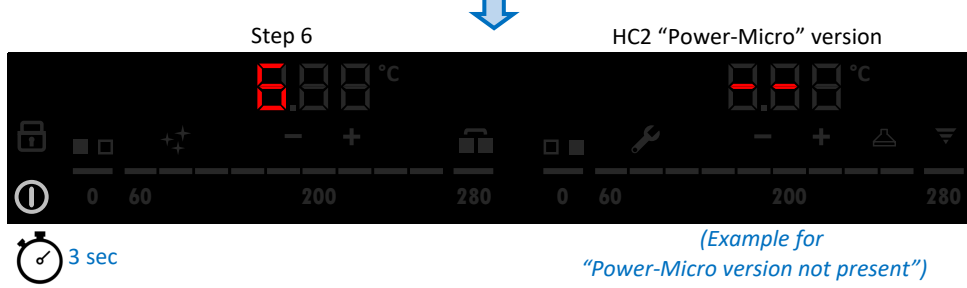

This step is present only for configurations with two power boards, meaning for Double Zone Frytop.



"BEEP"

Service utility S1 initial page

At the end of the sequence the UI automatically return to the Service utility S1 initial page.

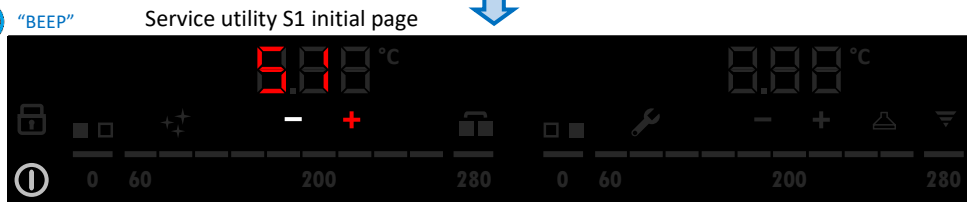

From here user can press "-" key to switch to "S2" service utility page, press On/Off key to exit SERVICE MENU or wait 8 sec to automatically exit from SERVICE MENU .

**NOTE:** Described sequence can be interrupted anytime pressing the On/Off key. The HUI will automatically return to **OFF** or **COOLING\_DOWN** state. All other keys are disabled.



# LIBERO LINE WOK INDUCTION

## 4.8.3.3 S2, SELF-DIAGNOSTIC TEST OF GENERATORS OFF

**Service Utility S2:** Power boards (POW) self-diagnostic test with induction generators OFF.

During this test there is no need to place pots on cooking zones. Induction generators are OFF (APD relay open), so meaning pot detection and power generation is not done.

The user enter the SERVICE MENU and select the "Service utility S2" item.

---

**UTILITY ACTIVATION:**  
User touch the "+" key to execute the utility.

---

**POWER BOARD SELF-TEST, GENERATOR OFF:**  
All connected power boards perform a self-diagnostic routine with the generators OFF (APD relay open). This takes about 30 seconds.

About 30 sec

---

**TEST RESULT:**  
At the end of the test a "BEEP" is generated to warn the user.  
Test result is showed for 5 seconds for every single cooking zone as in picture.

- "0" = Test OK
- "E" = Test failed



Service utility S2

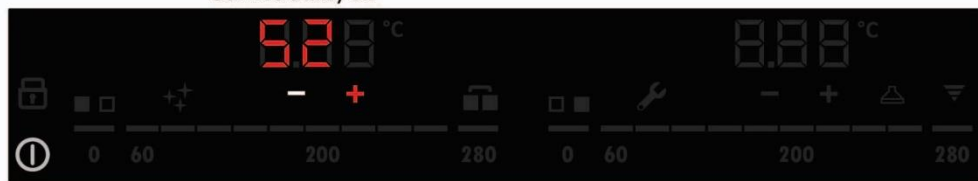

↓

"BEEP" Service utility S2

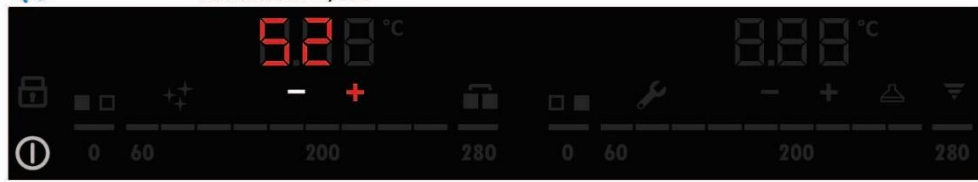

↓

Power board self-test, generators OFF



↓

"BEEP" Power board self-test, generators OFF



Test result on Single Zone configurations:  
**OK** on controlled cooking zone

.. OR ..

"BEEP" Power board self-test, generators OFF



Test result on Single Zone configurations:  
**Not OK** on controlled cooking zone

.. OR ..

# LIBERO LINE WOK INDUCTION

... CONTINUE FROM PREVIOUS ...

**TEST RESULT:**  
(Continue from previous).



**"BEEP"** Power board self-test, generators OFF

Test result on Double Zone configurations: **OK** on both cooking zones

**"BEEP"** Power board self-test, generators OFF

Test result on Double Zone configurations: **Not OK** on both cooking zones

**"BEEP"** Power board self-test, generators OFF

Test result on Double Zone configuration: **Not OK** for the generators assigned to the left part of the UI (Zone 1)

Test result on Double Zone configuration: **OK** for the generators assigned to the right part of the UI (Zone 2)

**"BEEP"** Power board self-test, generators OFF

Test result on Double Zone configuration: **OK** for the generators assigned to the left part of the UI (Zone 1)

Test result on Double Zone configuration: **Not OK** for the generators assigned to the right part of the UI (Zone 2)

At the end of the sequence the UI automatically return to the Service utility S2 initial page.

**"BEEP"** Service utility S2 initial page

From here user can press "-" key to switch to "S3" service utility page, press On/Off key to exit SERVICE MENU or wait 8 sec to automatically exit from SERVICE MENU

**NOTE:** Described sequence can be interrupted anytime pressing the On/Off key. The HUI will automatically return to **OFF** or **COOLING\_DOWN** state. All other keys are disabled.

# LIBERO LINE WOK INDUCTION

The user enter the SERVICE MENU and select the "Service utility S2" item.

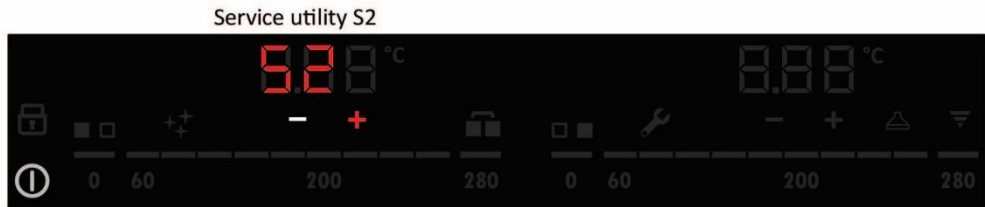

## UTILITY ACTIVATION:

User touch the "+" key to execute the utility.



## POWER BOARD SELF-TEST, GENERATOR OFF:

All connected power boards perform a self-diagnostic routine with the generators OFF (APD relay open).

This normally takes about 30 seconds but several attempts are done if the test is not performed.

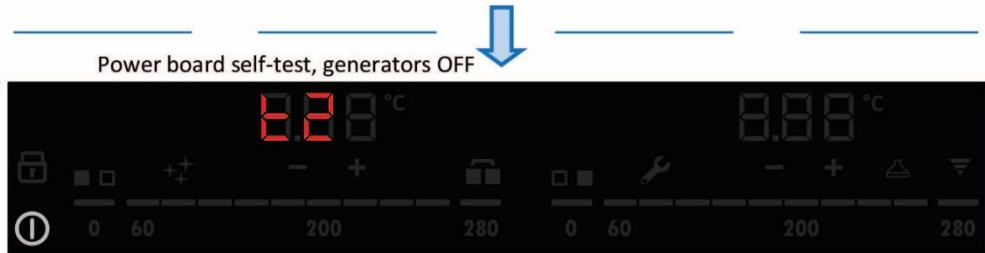
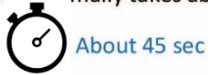

## TEST NOT EXECUTED:

The HUI is unable to perform the test, i.e. because MACS communication is broken.

In this case the UI automatically return to the Service utility S2 initial page without showing the test result.

No "BEEP" is generated.

From here user can press "-" key to switch to "S3" service utility page, press On/Off key to exit SERVICE MENU or wait 8 sec to automatically exit from SERVICE MENU.

**NOTE:** Described sequence can be interrupted anytime pressing the On/Off key. The HUI will automatically return to **OFF** or **COOLING\_DOWN** state. All other keys are disabled.

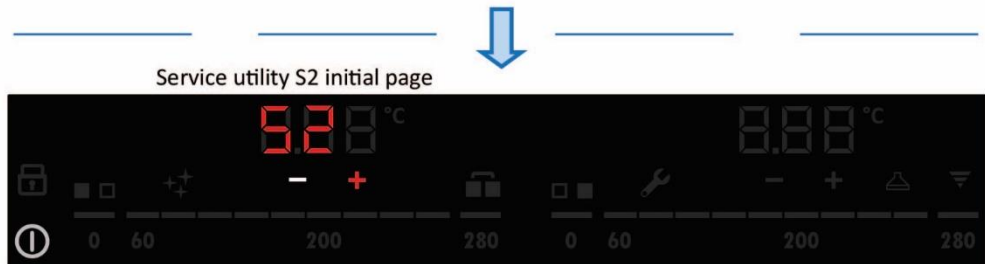

# LIBERO LINE WOK INDUCTION

## 4.8.3.4 S3, SELF-DIAGNOSTIC TEST WITH GENERATORS ON

**Service Utility S3:** Power boards (POW) self-diagnostic test with induction generators ON.

During this test the pan must be present in the cooking zone. Induction generators are ON (APD relay closed). Pot detection is executed. All generators (meaning all coils) on all cooking zones are ON at maximum power defined in the configuration (Level 9).

**NOTE:** This test is not always accurate. By repeating the test several times, it happens with a certain frequency that the equipment is unable to provide the result without a physical change having occurred on the equipment. On double zone appliances, most of the time only the result of POW1 (Zone 1, left digit) is showed whereas right digit stays off. Other times the result for POW2 appears after about 2 seconds.

The user enter the SERVICE MENU and select the "Service utility S3" item.

Cooking plate must be present on all cooking zones to pass the test.

Demo mode must be disabled to execute this test.

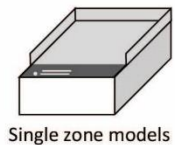
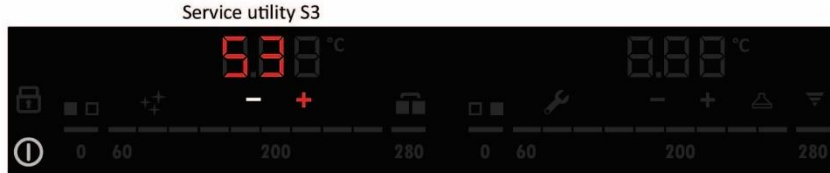

.. OR ..

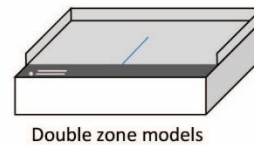

**UTILITY ACTIVATION:**

User touch the "+" key to execute the utility.

**POWER BOARD SELF-TEST, GENERATOR ON:**

All connected power boards perform a self-diagnostic routine with the generators ON (APD relay closed). This takes about 15 seconds.

Another "BEEP" is generated at the beginning of the test.

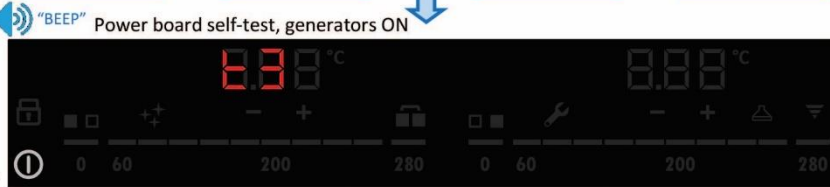

**NOTE:** There is only one power board connected (HC1) on FRY models, Single zone.  
There are two power board connected (HC1+HC2) on FRY models, Double zone.

⌚ About 15 sec

**TEST RESULT:**

At the end of the test a "BEEP" is generated to warn the user.

Test result is showed for every single cooking zone as in picture.

- "0" = Test OK
- "E" = Test failed

Visualization persist for 5 sec to 230 sec. This time is different according to the detected error.

⌚ 5 to 230 sec

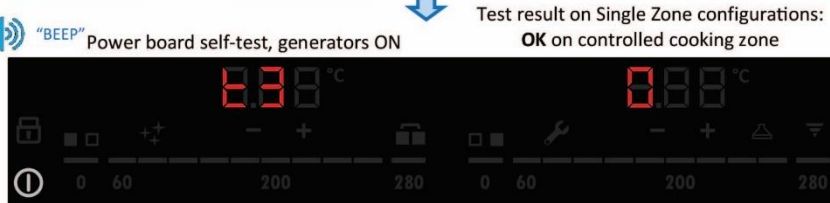

.. OR ..

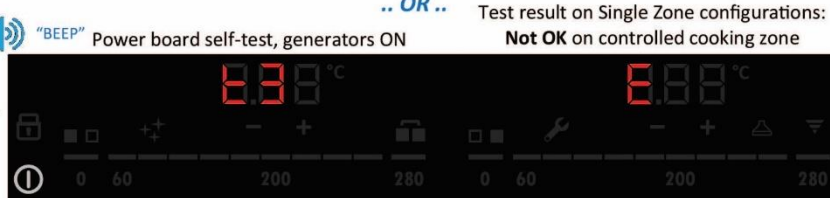

.. OR ..

... TO BE CONTINUED ...



# LIBERO LINE WOK INDUCTION

... CONTINUE FROM PREVIOUS ...

## TEST RESULT:

(Continue from previous).

 5 to 230 sec

 "BEEP" Power board self-test, generators ON

Test result on Double Zone configurations: **OK** on both cooking zones

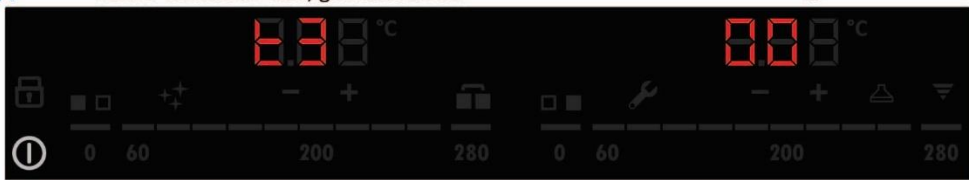

 "BEEP" Power board self-test, generators ON

Test result on Double Zone configurations: **Not OK** on both cooking zones

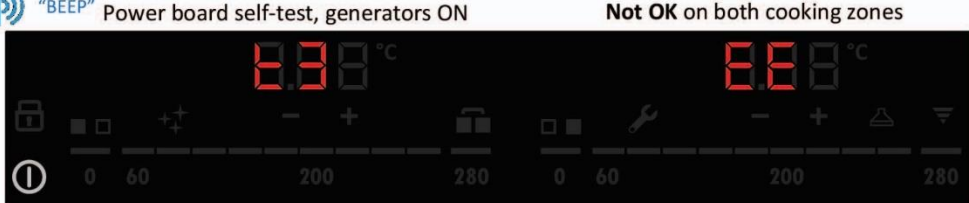

.. OR ..

Test result on Double Zone configuration: **Not OK** for the generators assigned to the left part of the UI (Zone 1)

Test result on Double Zone configuration: **OK** for the generators assigned to the right part of the UI (Zone 2)

 "BEEP" Power board self-test, generators ON

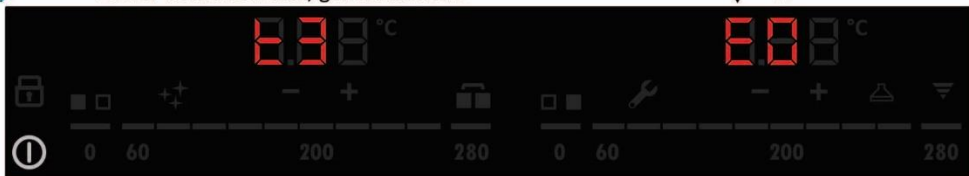



.. OR ..

Test result on Double Zone configuration: **OK** for the generators assigned to the left part of the UI (Zone 1)

Test result on Double Zone configuration: **Not OK** for the generators assigned to the right part of the UI (Zone 2)

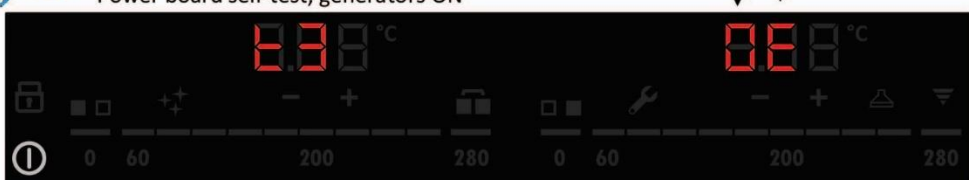
 "BEEP" Power board self-test, generators ON



 "BEEP" Service utility S3 initial page

At the end of the sequence the UI automatically return to the Service utility S3 initial page.

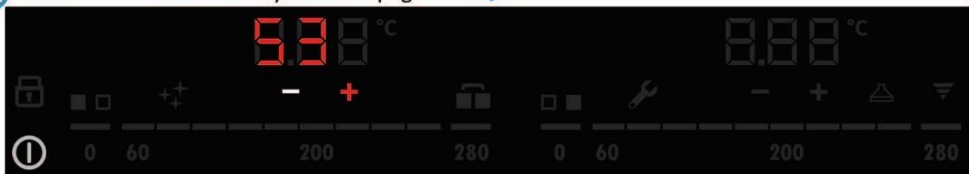

From here user can press "-" key to switch to "S4" service utility page, press On/Off key to exit SERVICE MENU or wait 8 sec to automatically exit from SERVICE MENU.

**NOTE:** Described sequence can be interrupted anytime pressing the On/Off key. The HUI will automatically return to **OFF** or **COOLING\_DOWN** state. All other keys are disabled.

**NOTE:** This test is not always accurate. By repeating the test several times, it happens with a certain frequency that the equipment is unable to provide the result without a physical change having occurred on the equipment.

# LIBERO LINE WOK INDUCTION

The user enter the SERVICE MENU and select the "Service utility S3" item.

Cooking plate must be present on all cooking zones to pass the test.

Demo mode must be disabled to execute this test.

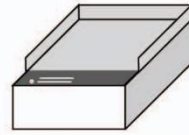
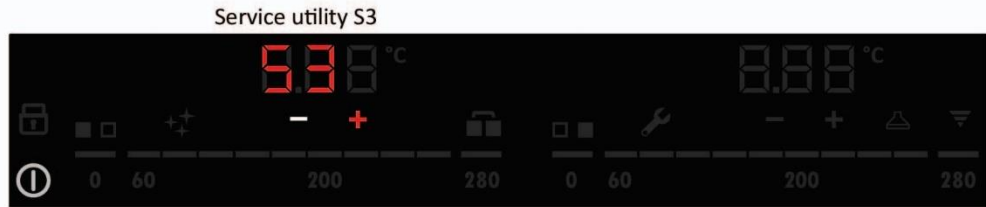

.. OR ..



## UTILITY ACTIVATION:

User touch the "+" key to execute the utility.

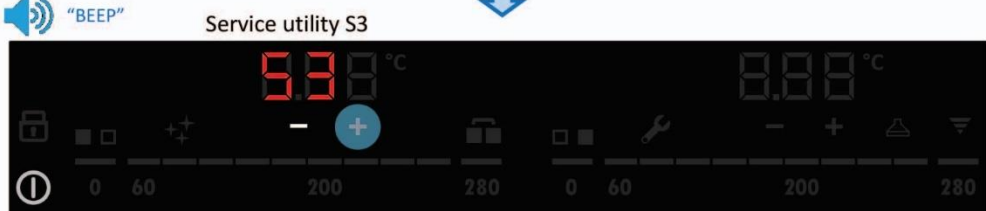

## POWER BOARD SELF-TEST, GENERATOR ON:

All connected power boards perform a self-diagnostic routine with the generators ON (APD relay closed).

Another "BEEP" is generated at the beginning of the test.

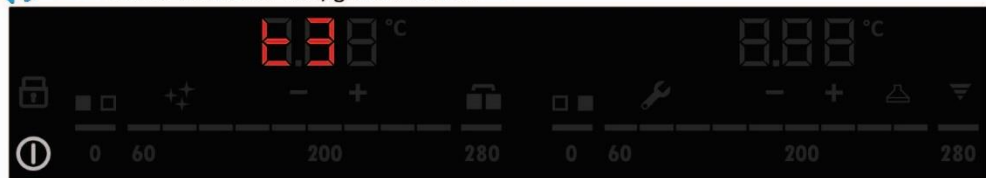

This normally takes about 30 seconds but several attempts are done if the test is not performed.

## TEST NOT EXECUTED:

The HUI is unable to perform the test, i.e.:

- MACS communication is broken;
- Demo mode is active.
- Cooking plate is not present on all cooking zones.
- Coils not connected.
- In general, the HC is in alarm.

In this case the UI automatically return to the Service utility S3 initial page without showing the test result.

No "BEEP" is generated.

From here user can press "-" key to switch to "S4" service utility page, press On/Off key to exit SERVICE MENU or wait 8 sec to automatically exit from SERVICE MENU.

**NOTE:** Described sequence can be interrupted anytime pressing the On/Off key. The HUI will automatically return to OFF or COOLING\_DOWN state. All other keys are disabled.

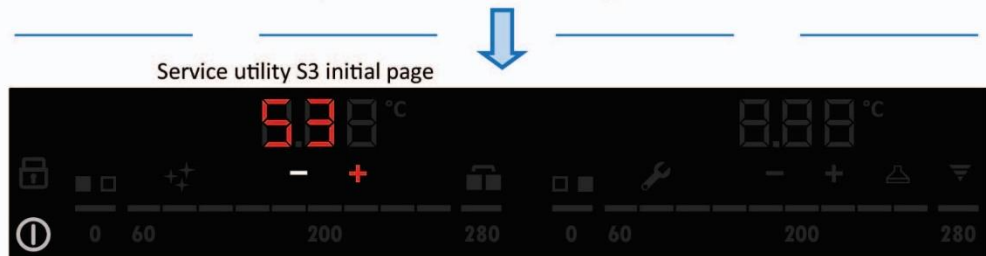

# LIBERO LINE WOK INDUCTION

## 4.8.3.5 S4, COOKING TOP COUPLING

This test is made to check the quality of the coupling between pans and generator.

Execute **Service Utility S4**: Power supply voltage + pot coupling rate.

During this test one pot must be present on one cooking zone (do not use empty pots as the appliance will carry out a real functions test / fill them with water).

The test involves one cooking zone only. If pots are detected in more than one cooking zones at the same time the test is performed in one zone only, randomly chosen. There is no indication on the U.I. of the cooking zone used for the test.

### NOTE !



- The test works only with **Tesla single-phase, generator**, 3500W. With Foucault POB the test apparently works but gives wrong values.

A quick explanation of how this test works.

The test is done in three steps:

- **Step 1:** The POW measures the main power supply voltage without load (zero power request).
- **Step 2:** The maximum power (equivalent to level 10) is requested to the cooking area under test. Real generated power is estimated measuring the current on the coil and a coupling factor is showed as:

Coupling factor % = (Estimated power / Requested power) %

Visualization is done as Px :

P0 → 0% to 9%

P1 → 10% to 19%

P2 → 20% to 29%

P3 → 30% to 39%

P4 → 40% to 49%

P5 → 50% to 59%

P6 → 60% to 69%

P7 → 70% to 79%

P8 → 80% to 89%

P9 → 90% to 100%

- **Step 3:** Main power supply voltage is measured with the cooking zone under test at max power.

Refer also to § PERFORMANCE.

# LIBERO LINE WOK INDUCTION

The user enter the SERVICE MENU and select the "Service utility S4" item.

Cooking plate must be present on at least one cooking zone to execute the test.

Demo mode must be disabled, otherwise the coupling factor will be 0%.

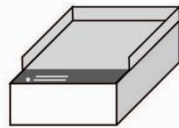
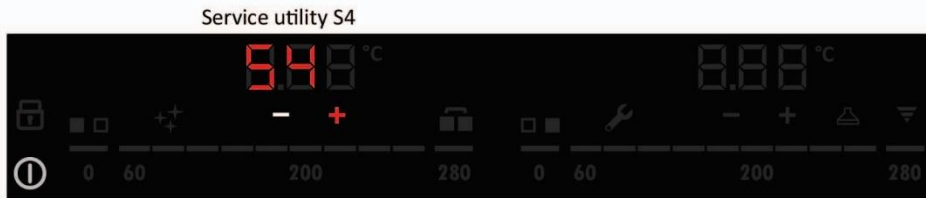

.. OR ..

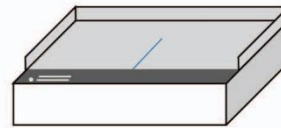

## UTILITY ACTIVATION:

User touch the "+" key to execute the utility.

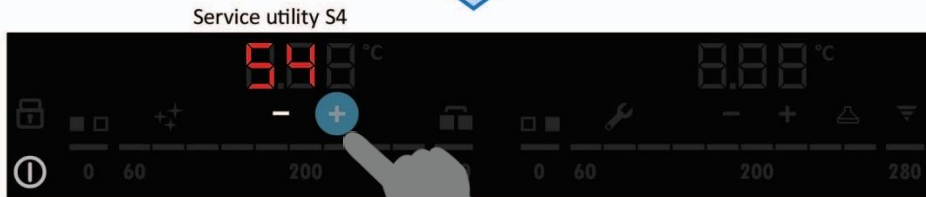

## STEP 1: MAIN VOLTAGE WITHOUT LOAD

No power is requested to the cooking zone under test.

Main power supply voltage is measured.

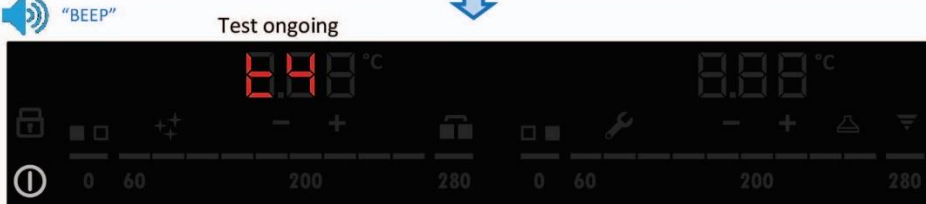

## STEP 1: MAIN VOLTAGE WITHOUT LOAD

Measured voltage is shown with the format "Ux" - "xx" as in picture.

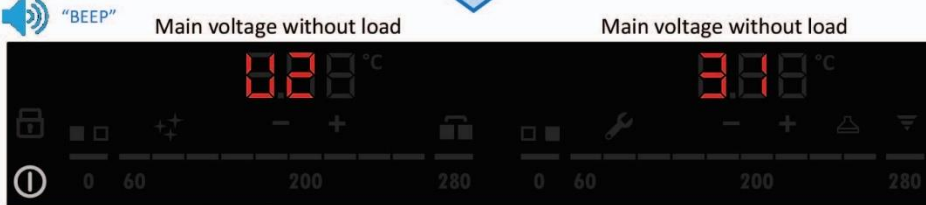

(Example for 231V)

## STEP 2: POT COUPLING

Max power is requested to the cooking zone under test.

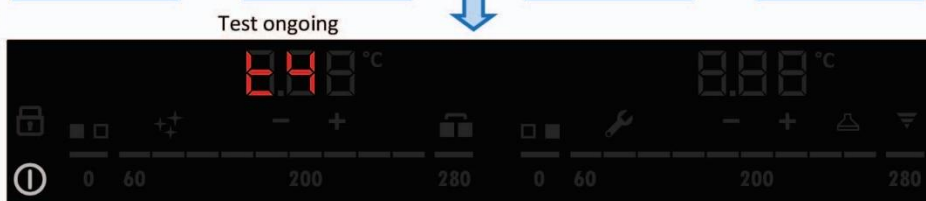

- Current absorption is measured and generated power is estimated.
- Main power supply voltage is measured.

... TO BE CONTINUED ...



# LIBERO LINE WOK INDUCTION

... CONTINUE FROM PREVIOUS ...

## STEP 2: POT COUPLING

Coupling factor is showed with the format "Px" as in picture.

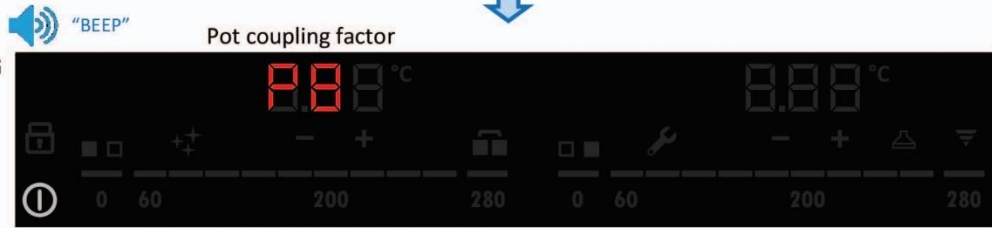

(Example for P8 → 80% to 89%)

## STEP 3: MAIN VOLTAGE UNDER LOAD

Measured voltage is shown with the format "Ux" – "xx" as in picture.

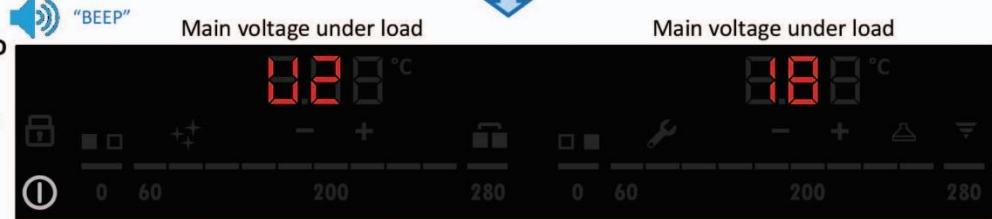

(Example for 218V)

At the end of the sequence the UI automatically return to the Service utility S4 initial page.

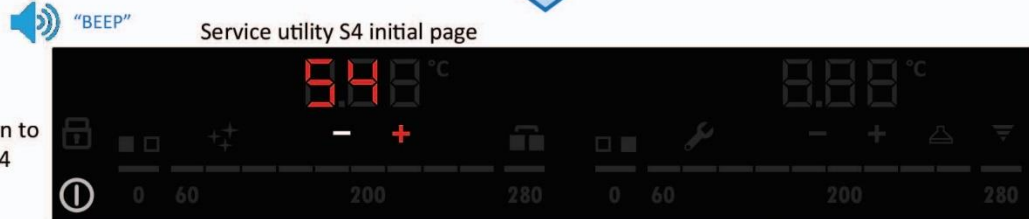

From here user can press "-" key to switch to "Demo mode" page, press On/Off key to exit SERVICE MENU or wait 8 sec to automatically exit from SERVICE MENU.

**NOTE 1:** Described sequence can be interrupted anytime pressing the On/Off key. The HUI will automatically return to OFF or COOLING\_DOWN state. All other keys are disabled.

**NOTE 2:** If an HC alarm is detected during the test the sequence is interrupted. Visualization on the UI is frozen. The UI automatically return to S4 initial page after a timeout (from 25 sec to 230 sec). The point where the sequence is interrupted and the timeout depends on the type of malfunction occurred.

**NOTE 3:** Ideally this test should be performed with the cooking plate mounted only on one of the cooking zones. For Double Zone equipment this is not possible. In this case the test will be executed anyway choosing randomly one of available cooking zones. There is no indication on the UI of the cooking zone used for the test.

**NOTE 4:** On Libero Line FRYTOP appliances every cooking zone is driven by a dedicated HC "Tesla" board; within the HC "Tesla" board, both generators Front and Rear are used. The test is only executed if pot detection is positive on Front Zone. On the opposite, if pot detection is negative for the Rear zone the test is performed anyway but coupling factor will be the half of the expected because Rear zone does not generate any power.

# LIBERO LINE WOK INDUCTION

## 4.8.4 HOB TO HOOD (H2H, SPECIAL FUNCTION)



### NOTE !

This special function is only available when the libero appliances are installed on board to a LIBERO POINT appliance.

This function is accessible directly on the U.I of the libero line appliances and does NOT need to be accessed (like service menu or customer menu). How does this function work: The Libero Line appliances are equipped with an I.F (infra-red) communication sensor located under the U.I glass; this sensor will communicate and send data to the I.R port located on the left side of the libero point appliance.



The “hob to hood” H2H icon and button are used in association with two internal functions: Automatic and Manual “hood” Fan Speed regulation.

Be aware, in below description, that rules for the button and for the icon color are different, depending to the function currently active.

## 4.8.5 MANUAL FAN SPEED

With this function, by pressing the H2H icon, the customer interrupts the automatic fan speed regulation and can decide manually what speed to set on the “hood” of the libero point.

With the Manual Fan Speed the user has the possibility to select desired hood fan speed from speed zero (meaning fan OFF) to speed 4 (max) by repeatedly pressing the H2H button on the U.I of the appliance.

This function is always available when the UI is **ON**, no matter if cooking zones are **IDLE**, **STANDBY** or **COOKING** sub-state.

When U.I. enters an **ON** state the manual Fan Speed is not active. Fan speed is initially set to zero and will eventually change depending on Automatic Fan Speed algorithm.

Pressing the H2H button the Manual Fan Speed mode is automatically activated. Once manually selected, fan speed is maintained up to when the U.I. turns in **OFF** or **COOLING\_DOWN** states.

Manual Fan Speed regulation is not available when the U.I. is **OFF** or **COOLING\_DOWN**. H2H button will be inactive.

Manual Fan Speed regulation is not available during cleaning special function. H2H button is inactive and the icon is off. Despite of this, automatic fan speed regulation continues during cleaning.

If the appliance is turned off the Manual Fan Speed setting is lost.

Manual fan operation overrides the Automatic Fan Speed regulation.

# LIBERO LINE WOK INDUCTION

UI in **ON** state.  
Cooking zones are **STANDBY** or **COOKING**  
*(Example only, same logic applies to Single Zone configurations)*

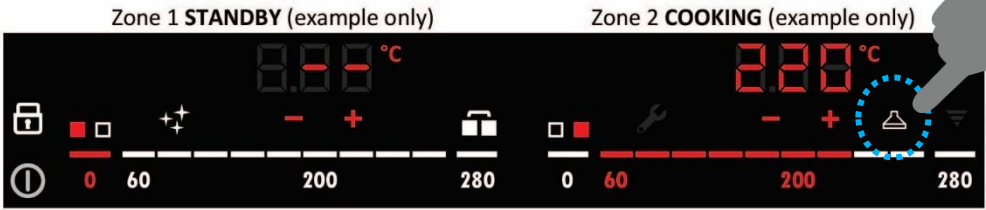

Manual Fan Speed function still not active, meaning that the user never touched the H2H key since the UI is in ON state.  
H2H key maybe white or red, depending on Automatic Fan Speed.  
In this example is supposed that H2H icon is white, meaning hood fan speed zero.

**MANUAL FAN SPEED ACTIVATION:**  
User touch the H2H key.  
Manual Fan Speed is now active @ Speed 1.  
H2H key became red.

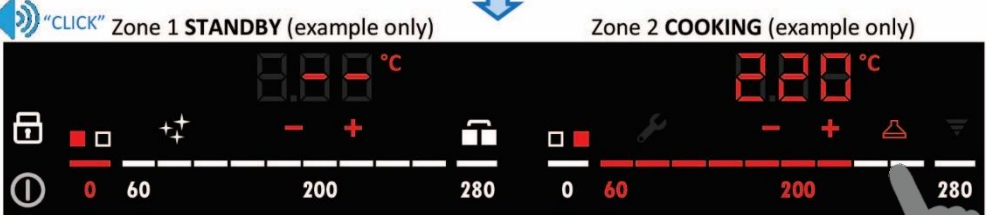

**MANUAL FAN SPEED REGULATION:**  
User touch the H2H key.  
Manual Fan Speed still active.  
Fan speed increased to Speed 2.  
H2H key still red.

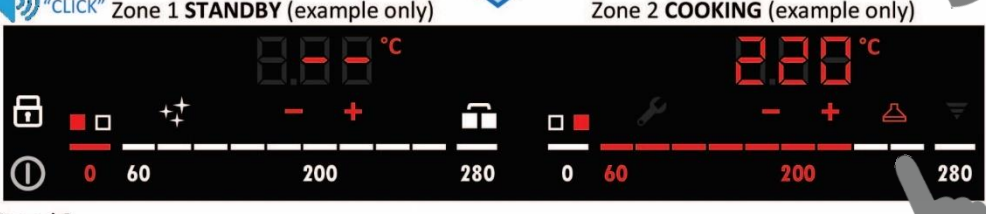

## 4.8.6 AUTOMATIC FAN SPEED:

This function automatically regulates the “hood” fan speed according to operating conditions on the cooking zones. The appliance cannot see how much vapor/smoke we are producing when cooking but it can “see” the temperature of the cooking surfaces... the algorithm works like this “hotter the surfaces= more steam = more hood suction level”; colder the surfaces= less vapor = less need of hood suction”.

The Automatic Fan Speed algorithm is operative both in **ON** and **OFF** state when Manual Fan Speed mode is not active.

H2H button is not used for Automatic Fan Speed but just for Manual Fan Speed regulation.

Automatic fan speed signals are sent also during Cleaning or even if there is an POW error. Required speed maybe wrong when the error involves a temperature sensor because temperature reading is unreal.

### H2H ICON:

Regardless of whether Manual or Automatic Fan Speed mode is active, H2H icon indicated the required hood fan speed as follow:

**ON state:** White when is required speed zero (hood fan off), red when is required hood fan speed different from zero.

**OFF state:** Off when is required speed zero (hood fan off), red when is required hood fan speed different from zero.

**NOTE:** During Cleaning the H2H icon is forced OFF. Despite of this, automatic fan speed regulation continues according to cooking surface temperature.

# LIBERO LINE WOK INDUCTION

UI in **ON** state.  
Cooking zones are **STANDBY** or **COOKING**  
*(Example only, same logic applies to Single Zone configurations)*



Manual Fan Speed function still not active, meaning that the user never touched the H2H key since the UI is in ON state.  
H2H key initially white, meaning that Automatic Fan Speed function has not yet begun to adjust the speed since the UI is in ON state.

## **AUTOMATIC FAN SPEED REGULATION:**

Manual Fan Speed function not active.

According to zone conditions, Automatic Fan Speed function adjust the speed.

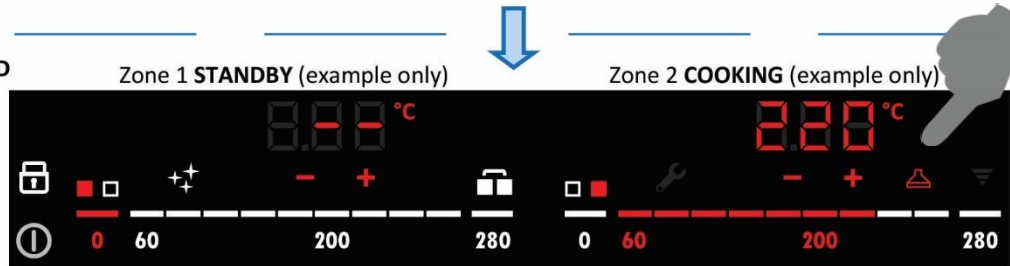

When speed is different from zero the H2H icon became red.  
No sound is generated during Automatic Fan Speed regulation.

# LIBERO LINE WOK INDUCTION

## 4.8.7 ALARMS

Alarms on Libero Line appliances are codified using four characters as follow:

**HUI** Hob User Interface / **HC** Hob Control. Also referred as “Power Board” (POW).

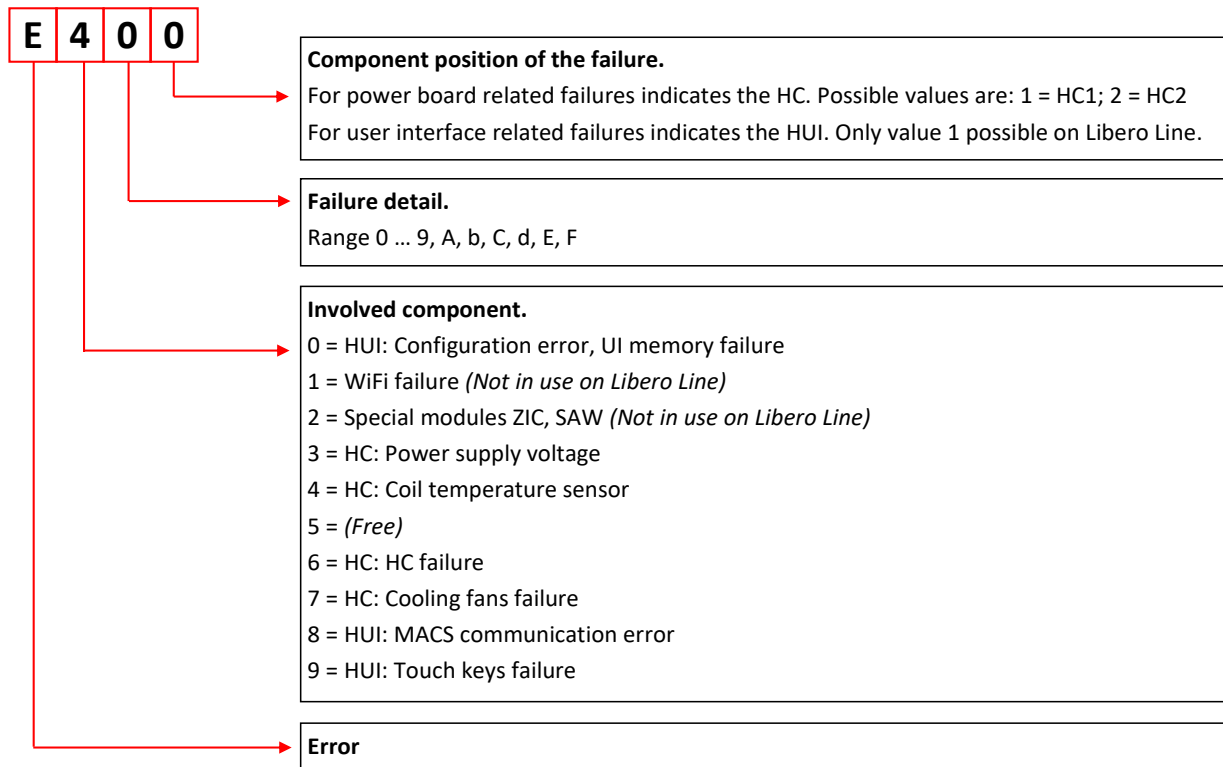

The alarm code appears:

- **For User Interface (U.I.) errors:** Some codes appear on left display only, some other are replicated on both display. No matter if the appliance is single or double zone.
- **For power board (POW) errors:** The error appears on the U.I. zone associated to the generator in error or unable to work as a consequence of the malfunction. So, meaning:
  - In one display only when the alarm impact only one generator inside a specific POW (e.g. E411: Coil temperature sensor open/not connected). Visualization is done on the U.I. zone associated to the defective generator. This is done to allow technician to correctly identify the failed component.
- Be aware that in some cases more than one generators are controlled by one Zone in the U.I. (e.g. for the Single zone Fry Top). In this case the error of both generators is showed in the same U.I. zone. There is not a specific way to indicate which generator is actually in error.
  - Replicated on both display if the problem impact on more than one generators and these generators are controlled by different zones on the U.I. (e.g. E321: Power supply undervoltage).
  - Replicated on both display if there is more than one error associated to different zones in the U.I.. Theoretically speaking, different specific codes should be showed on every U.I. zones. By design choice instead just one code (the latest discovered in chronological order) is replicated on all U.I. zones in error.

# LIBERO LINE WOK INDUCTION

**NOTE:** Depending on the alarm code and configuration in use, visualization can be replicated on both display or showed on one zone only.

**STEP 1:**

First two characters of the alarm code are showed for 1 sec.

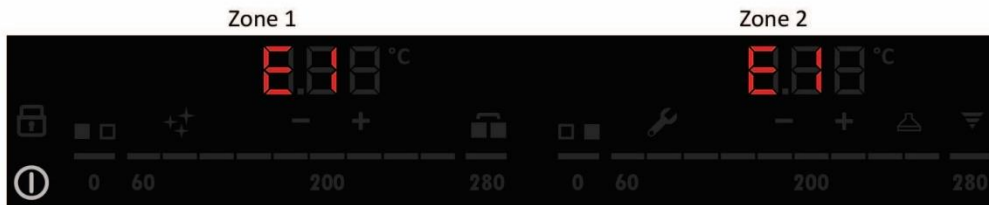

**STEP 2:**

Last two characters of the alarm code are showed for 1 sec.

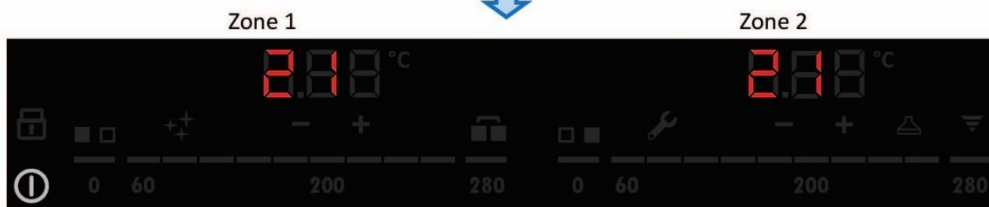

**STEP 3:**

Display off for 0.5 sec

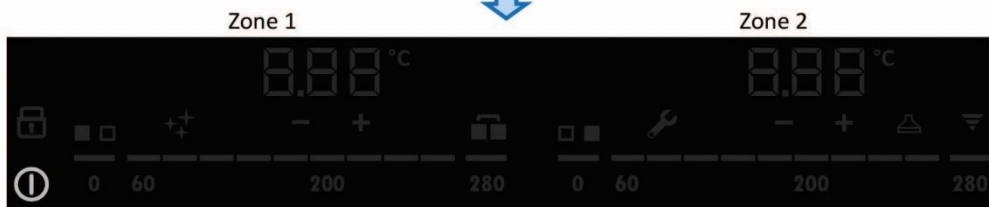

**NOTE: E1 21 IS AN INVENTED ALARM JUST FOR ILLUSTRATION PURPOSE!!.**



# LIBERO LINE WOK INDUCTION

## 4.8.7.1 ALARM CODE LIST

This alarm list is generic for all libero line appliances that have Tesla or Foucault generator.

Refer also to the § GLOSSARY AND ABBREVIATIONS

Alarm code	Involved component	Power disable	Self-resetting	Alarm name	Alarm description	Alarm trouble shooting
E031	U.I	Yes	No	UI_CFG_ALM	Missing configuration or defect CRC of complete configuration block. The alarm is showed on left display only. NOTE 1: With Tesla POW only, HOB and WOK application this alarm is overridden by E821 after about 30 seconds. NOTE 2: With Tesla POW only, FRYTOP application this alarm at first overridden by E441 in about ten seconds, then overridden by E821 after about 30 seconds. NOTE 3: This alarm prevents entering on CUSTOMER and SERVICE menu.	Wrong spare part, communication cable disconnected
E311 E312	POW	Yes	Yes	400V_DETECTION	<b>Tesla POW only:</b> Power supply overvoltage. Its purpose is to detect wrong phase-to-phase connection (400V instead of 230V).	Check voltage
E321 E322	POW	No	Yes	LOW_MAINS_VOLTAGE	Too low power supply voltage. <b>Tesla POW:</b> About 150V for detection, 160V for reset (internal induction circuits measure, after APD relay). <b>Foucault POW:</b> About 310V for detection and reset, no hysteresis (internal induction circuits measure, after APD relay). About 10 seconds under the threshold are required to generate the error.	Check voltage
E401 E402	POW	Yes	Yes	TEMP SENS FMEA_Z0 (Front zone on Tesla POW) TEMP SENS FMEA_Z1 (Rear zone on Tesla POW)	Coil safety temperature sensor bad circuit or short circuit. Bad circuit means temperature $\geq 290^{\circ}\text{C}$ on Tesla POW. Bad circuit means temperature $\geq 300^{\circ}\text{C}$ on Foucault POW. For <b>Tesla POW, HOB &amp; WOK</b> , diagnostic is executed on both generators (Front and Rear) even if not really used in a specific configuration, i.e. in a single zone configuration. For this reason, a dummy sensor (100kOhm resistance) must be connected on the unused input.	Check temp sensors
E411 E412	POW	Yes	Yes	TEMP SENS OPEN_Z0 (Front zone on Tesla POW) TEMP SENS OPEN_Z1 (Rear zone on Tesla POW)	Coil safety temperature sensor open or not connected. For <b>Tesla POW, HOB &amp; WOK</b> , diagnostic is executed on both generators (Front and Rear) even if not really used in a specific configuration, i.e. in a single zone configuration. For this reason, a dummy sensor (100kOhm resistance) must be connected on the unused input.	Check temp. sensors
E421 E422	POW	Yes/No	Yes	ZONES HI-TEMP	<b>Tesla POW, HOB &amp; WOK:</b> Overtemperature on front or rear coil (measured on coil safety sensor). The error is unique for all temperature sensor inside an POW. $260^{\circ}\text{C}$ for activation, $215^{\circ}\text{C}$ for deactivation. No slope control. <b>Tesla POW, FRYTOP:</b> Overtemperature on front or rear coil (measured on coil safety sensor and plate temperature sensor). The error is unique for all temperature sensor (coil safety + plate) inside an POW. Coil safety sensor: $140^{\circ}\text{C}$ for activation, $95^{\circ}\text{C}$ for deactivation. No slope control. Plate temperature sensor: $290^{\circ}\text{C}$ for activation, no self-resetting. No slope control. <b>Foucault POW, HOB &amp; WOK:</b> Overtemperature on coil safety sensor. $280^{\circ}\text{C}$ for activation, $255^{\circ}\text{C}$ for deactivation. In addition, starting $150^{\circ}\text{C}$ the alarm is also arisen by a too fast temperature increment. In this case the alarm is not self-resetting.	Check cleaning filters, cleaning of ventilators fans (dirt accumulation on fan blades)

# LIBERO LINE WOK INDUCTION

Alarm code	Involved component	Power disable	Self-resetting	Alarm name	Alarm description	Alarm trouble shooting
E431 E432	POW	Yes	Yes	TEMP SENS SLOPE_Z0 (Front zone on Tesla POW)  TEMP SENS SLOPE_Z1 (Rear zone on Tesla POW)	<b>Implemented on Tesla POW only:</b> Slope detection alarm (temperature not increasing, stuck,) on front or rear coil. This diagnostic is only active when zone temperature is below 55°C. Intervention time depends on requested power: <ul style="list-style-type: none"> <li>Level 8, 9, 10 : 2 min 30 sec</li> <li>Level 7 : 4 min 30 sec</li> <li>Level 5, 6 : 7 min</li> <li>Level 4 : 9 min 30 sec</li> <li>Level 3 : 14 min</li> <li>Level 1,2 : More than 3h</li> </ul> The error is self-resetting after two minutes that the U.I. is OFF or COOLING_DOWN state. <b>NOTE:</b> For Tesla POW with single zone configurations this diagnostic help to diagnose the reversal of the sensor with the dummy resistor (100kOhm resistance).	Check temp sensors, DUMMY sensor has been swapped position after .Part replacement.
E441 E442	POW	Yes/No	Yes	PLATE_TEMP_SE NSOR_Z0 (Front zone on Tesla POW)  PLATE_TEMP_SE NSOR_Z1 (Rear zone on Tesla POW)	<b>Tesla HC, HOB &amp; WOK:</b> Wrong electrical connection: A cooking plate temperature sensor is present on BT300 or BT400 connector. In this case the error is not self-resetting. <b>Tesla POW, FRYTOP:</b> Two possibilities: Cooking plate temperature sensor open, not connected, bad circuit or short circuit. Bad circuit means temperature $\geq 290^{\circ}\text{C}$ on Tesla POW. HOB or WOK configuration loaded in a FRYTOP appliance. The error is self-resetting in case of sensor open or not connected, not self-resetting in case of bad circuit or short circuit. <b>NOTE:</b> Diagnostic is executed on both generators (Front and Rear) within the single Tesla POW § <u>S3. SELF-DIAGNOSTIC TEST WITH GENERATORS ON.</u>	Check temp sensors, DUMMY sensor has been swapped position after Spare Part replacement
E501	U.I	No	No		The alarm is showed on both display (left and right). On Libero Line this may happen when a wrong firmware is used for the hardware.	Check correct U.I. spare part
E601	POW	No	Yes	15V BAD	15 Volt supply out of window	Check voltage on POW
E611 E612	POW	Tesla : Yes  Foucault: No	Yes	Tesla: IGBT_TEMP_SENS Fouc: SENS_ERR_IGBT	<b>Tesla POW:</b> IGBT/heat-sink sensor open or short or $>130^{\circ}\text{C}$ ( $115^{\circ}\text{C}$ for deactivation). One single error for both IGBT temperature sensors within an POW. <b>Foucault HC:</b> IGBT/heat-sink sensor open or short. The error is self-resetting	Overheating, Check cleaning filters, cleaning of ventilators fans (dirt accumulation on fan blades)
E641	POW	Yes	Yes	RELAY GLUED	APD relay glued, can't switch off power induction circuits.	Check POW
E651	POW	Yes	Yes	ADJACENT ADC PIN FMEA ERROR	Solder/assembly fault inside power board: short circuit on adjacent pin of safety ADC. <b>NOTE:</b> On Tesla POW, this error appears (on both generators) if a coil temperature sensor is disconnected / reconnected when the POW board is already powered on.	Check temp sensors connectors
E661	POW	Yes	No	DATA_CRC_ERROR	<b>Foucault POW only:</b> Internal power table missing. Foucault POW software is equipped with an internal power table to be used when the POW is connected without an UI and power level set is established by a potentiometer (modular cooking range). Even if not used on Libero Line, the POW software check the presence of the internal power table at power-on	Wrong spare part.
E6A1	POW	Yes	Yes	MAINS FREQUENCY ERROR	Power supply frequency detection error. Acceptable range: 40% to 60% of the duty cycle @50Hz.	Check Power supply frequency



# LIBERO LINE WOK INDUCTION

Alarm code	Involved component	Power disable	Self-resetting	Alarm name	Alarm description	Alarm trouble shooting
E701 E702	POW	Tesla : Yes	Yes	Tesla: BOARD_FAN_ERROR	<p><b>Tesla POW:</b> IGBT cooling fan blocked or not connected. Remarks:</p> <ul style="list-style-type: none"> <li>The alarm is reset when the U.I. stay at least 120sec of <b>OFF</b> or <b>COOLING_DOWN</b> state, no matter if problem is solved or not.</li> <li>About 20 sec before the alarm occurs POW sent pot fail state to the U.I.</li> </ul> <p><b>Foucault HC:</b> One or more internal cooling fan blocked/not connected/not following. Power disable depend on number of fans blocked</p>	Check cooling fan of POW
E711 E712	POW	Yes	Yes	EXTERNAL_FAN_ALARM	<p><b>Tesla POW only:</b> External tangential fan blocked or not connected.</p> <p>Remarks: The alarm is reset when the U.I. stay at least 120sec of <b>OFF</b> or <b>COOLING_DOWN</b> state, no matter if problem is solved or not.</p>	Check cooling fan
E821 E822	U.I	Yes	Yes	POW_COMM_WDOG_ALM	<p>U.I1 detects POW1/POW2 communication timeout. The alarm is showed on left display only (Both 821 and 822).</p> <p><b>NOTE:</b> This alarm maybe generated by:</p> <ul style="list-style-type: none"> <li>A wrong MACS connection between U.I and POW</li> <li>A missing or wrong ID jumper on POW board.</li> </ul> <p>With appliance with more than one POW (e.g. Double Zone Fry top) it's still possible to work with one zone only when the other one is in error.</p>	Check communication cables POW to U.I.
E831 E832	U.I	Yes	Yes	MACS_ACK_TOUT	<p>U.I1 detects MACS acknowledgements missing to POW1. This alarm appears if communication is lost during standard operation. The alarm is overridden by E821 after some seconds. The alarm is showed on both display.</p>	Check communication cables POW to U.I.
E911	U.I			BUTTON_LOW_REF	Touch button failure	Check U.I.
E921	U.I			BUTTON_LOW_SIGNAL	Touch button failure	Check U.I.
E931	U.I			BUTTON_HIGH_REF	Touch button failure	Check U.I.
E941	U.I			BUTTON_HIGH_SIGNAL	Touch button failure	Check U.I.
E981	U.I			BUTTON_ERROR - Init	Touch button failure	Check U.I.
E991	U.I			BUTTON_ERROR - Run time	Touch button failure	Check U.I.
E9A1	U.I			BUTTON_ERROR - FMEA Library	Touch button failure	Check U.I.
E9b1	U.I			BUTTON_ERROR - FMEA short	Touch button failure, the alarm is showed on both display.	Check U.I.
E9C1	U.I			BUTTON_ERROR - FMEA open	Touch button failure, the alarm is showed on both display.	Check U.I.

## NOTE !



If the filters start to get dirty and limit the fresh air passage, before emitting an “over heating alarm E421” the appliance will start to limit the energy emission of the POW, a typical call from a customer could be “ the appliance is not performing any more” or “ after some time the appliance is not performing”.

## 4.9 SOFTWARE UPDATE & WIFI

The software update is not possible on the electronic boards. WIFI is not implemented at this moment.

# LIBERO LINE WOK INDUCTION

## 5 TROUBLESHOOTING

---

The following chapters are intended only for authorized technicians / engineers

### 5.1 ALARM TROUBLESHOOTING

Refer to the alarms described at § [ALARM CODE LIST](#)

## 6 SERVICING THE APPLIANCE

---

The following chapters are intended only for authorized technicians / engineers



### WARNING !

Take GREAT CARE when connecting / testing anything with live current, if you are unsure what you are doing and how to use your equipment safely, then **DON'T DO IT.**

### 6.1 LIST OF NEEDED TOOLS

Complete Socket & Wrench set (from 6 to 24)

Complete allen key set

Bent long nose pliers

Screwdrivers Philips "small / medium / large"

Screwdrivers flat "small / medium / large"

Clamp amp meter

Multimeter (voltage reader)

Tongue groove pliers (water & gas pipes)

Grip lock plier

Protective gloves (heatproof / cut proof)

Refer also to the § [PERSONAL PROTECTION EQUIPMENT](#)

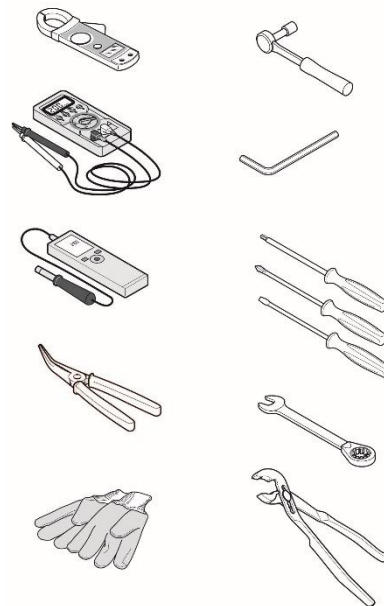

# LIBERO LINE WOK INDUCTION

## 6.2 DISASSEMBLY/REASSEMBLE OF COMPONENTS

This chapter explains how to remove various parts of the equipment to access its functional components: please always refer to this guide to access various parts.

To locate the component of interest, please refer to the following § and illustrations. Each component is marked with a name/number and a page which explains in detail how to take it apart.



### WARNING / CAUTION !

Before any operation on the machine read Chapter SAFETY INFORMATION/PRECAUTIONS. We recommend for any phase involving the removal of the components to use cut-resistant gloves

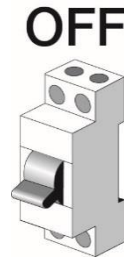

# LIBERO LINE WOK INDUCTION

## 6.2.1 APPLIANCE CASING

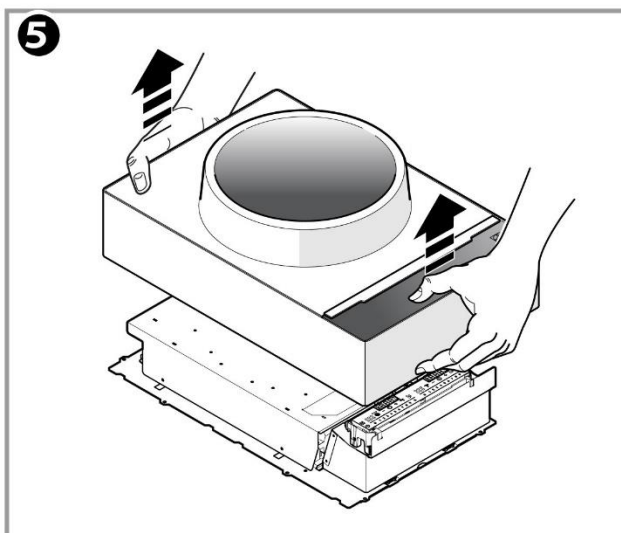
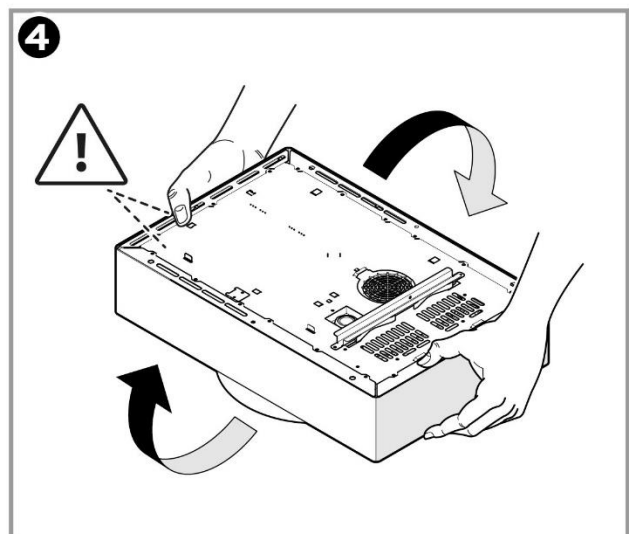
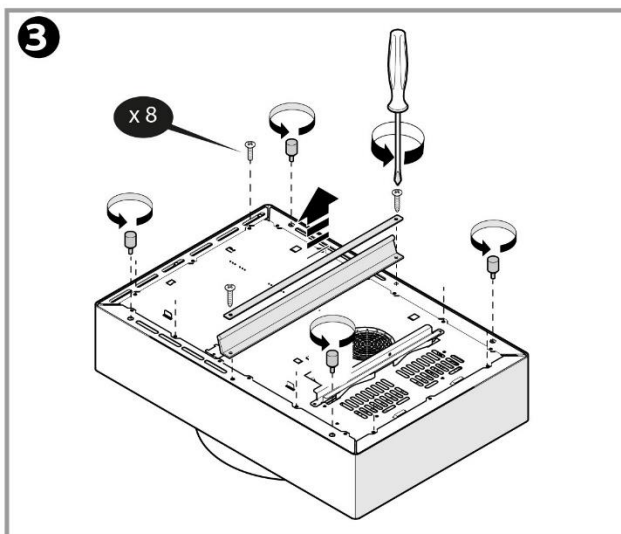
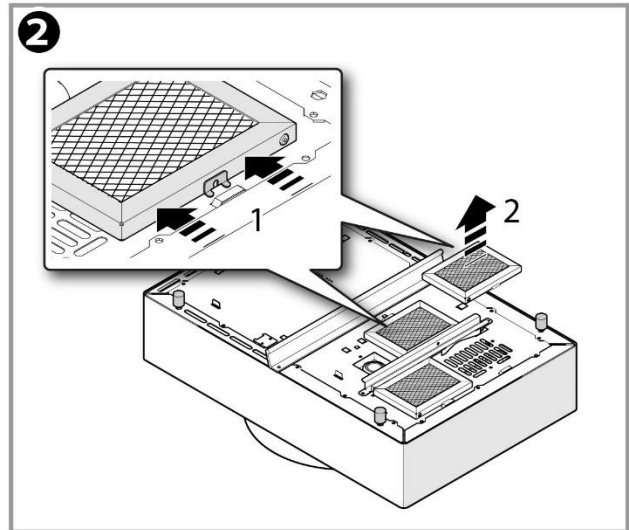
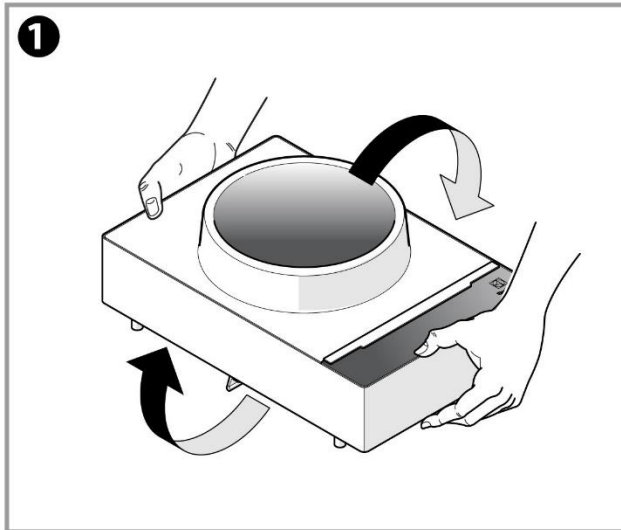

# LIBERO LINE WOK INDUCTION

## 6.2.2 COMPONENTS APPLIANCE 3500W

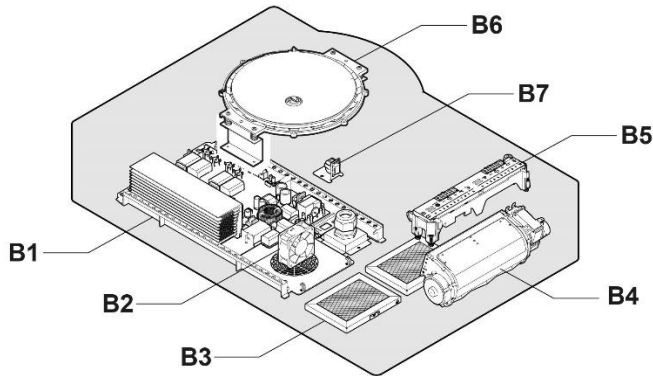

Pos.	Component	§.
B1	Generator POB, TESLA	<u>GENERATOR POB TESLA</u>
B2	Ventilator	<u>VENTILATOR</u>
B3	AIR Filters	<u>AIR FILTERS</u>
B4	Ventilator tang M1	<u>USER INTER-FACE, U.I. &amp; VENTILATOR (TANGENTIAL)</u>
B5	User board	<u>USER INTER-FACE, U.I. &amp; VENTILATOR (TANGENTIAL)</u>
B6	Coils & temperature sensors	<u>COILS</u>

### 6.2.2.1 GENERATOR POB TESLA

Remove the appliance casing § APPLIANCE CASING, then:

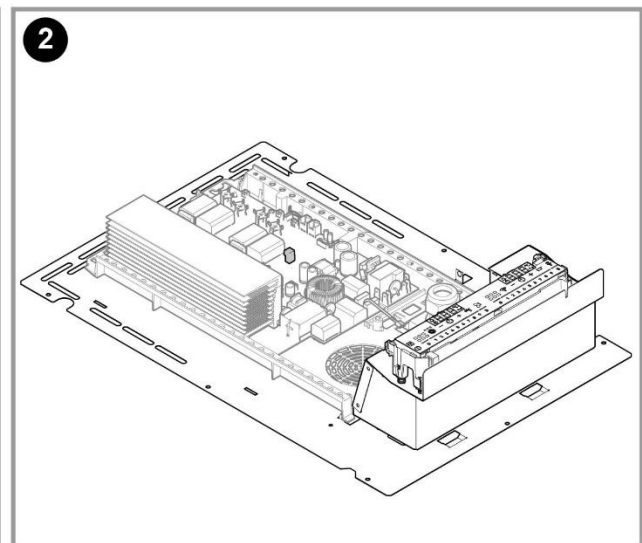
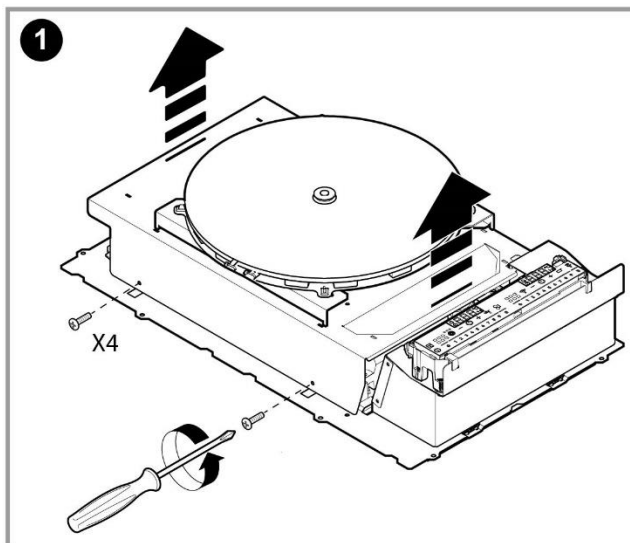

# LIBERO LINE WOK INDUCTION

## 6.2.2.2 VENTILATOR

Remove the appliance casing § APPLIANCE CASING, then:

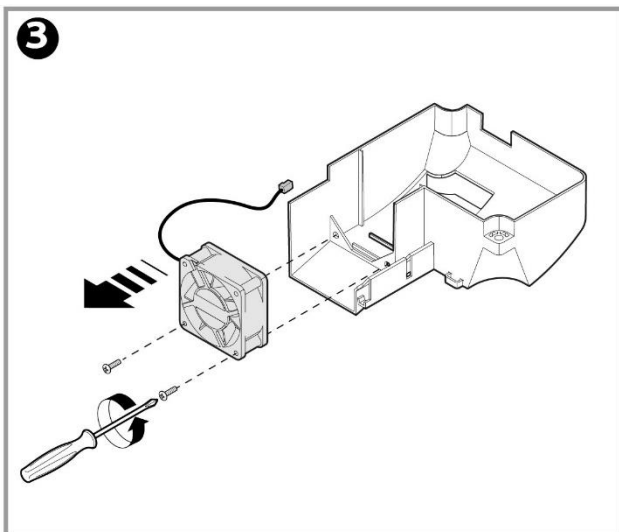
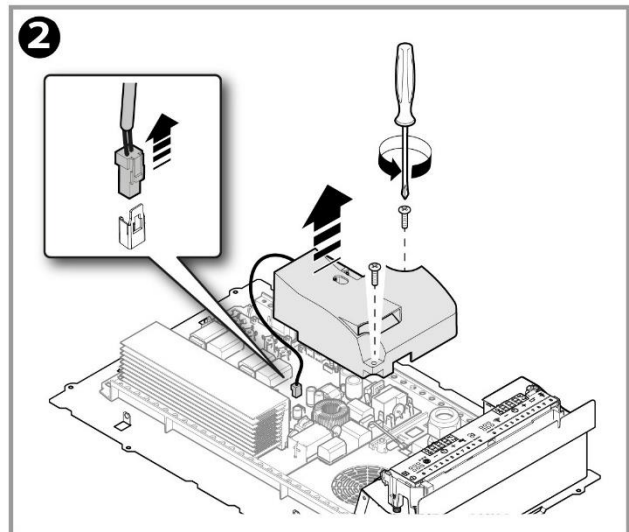
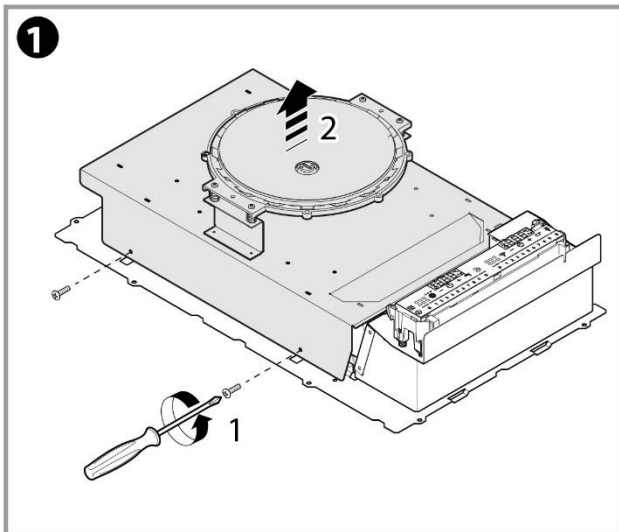

## 6.2.2.3 AIR FILTERS

The air filters can be washed separately or inserted into a dish washing machine, dry carefully or leave to dry on a dish rack or towel. In case of clogging up the appliance can over heat and generate an alarm

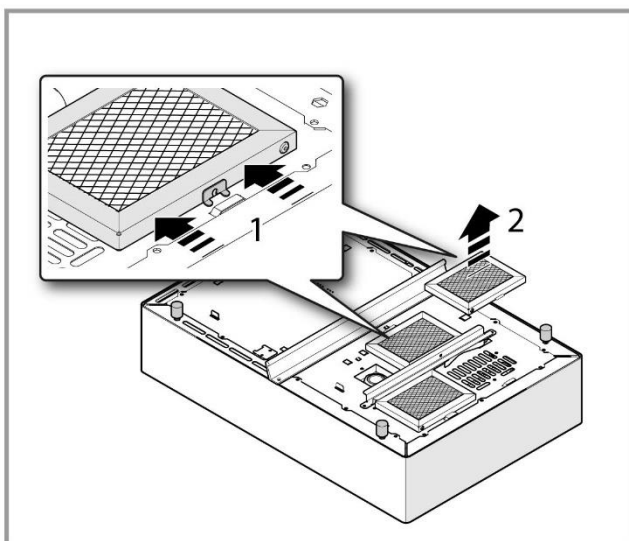
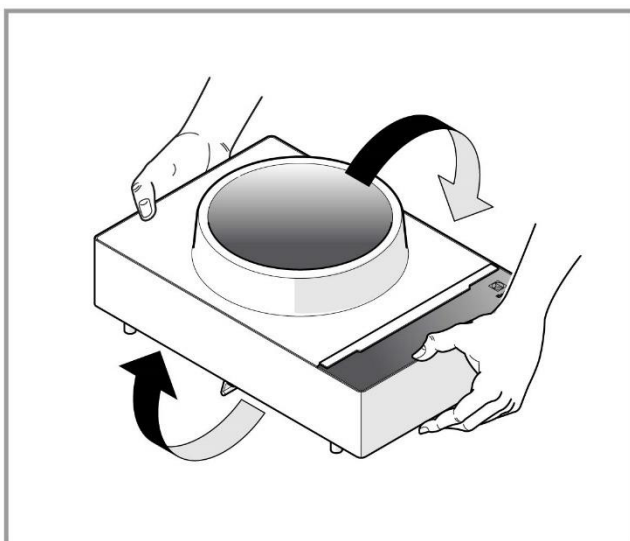

# LIBERO LINE WOK INDUCTION

## 6.2.2.4 USER INTERFACE, U.I. & VENTILATOR (TANGENTIAL)

Remove the appliance casing § APPLIANCE CASING, then:

The U.I is fixed onto springs into slots in the paneling.

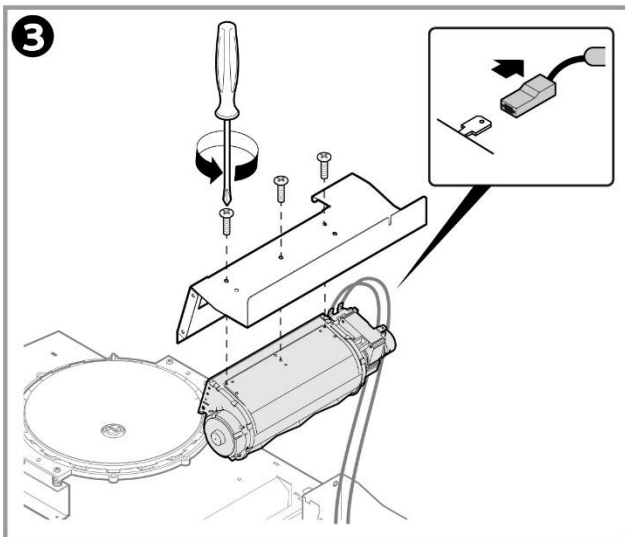
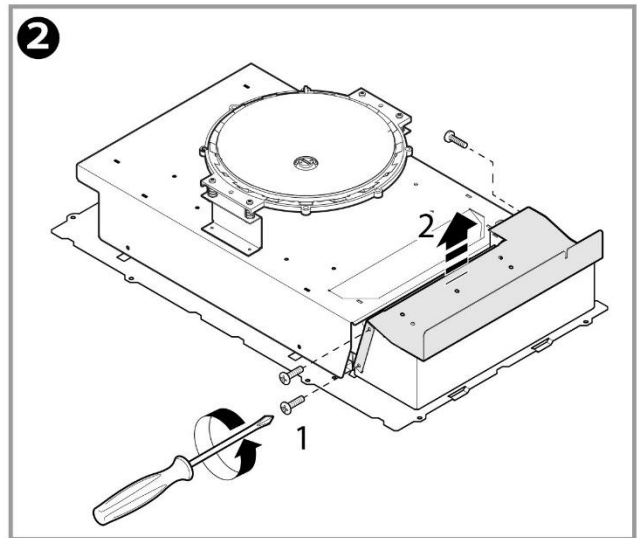
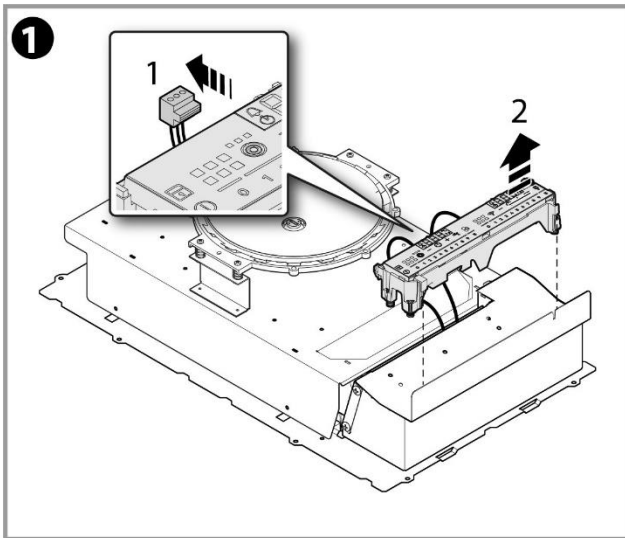

# LIBERO LINE WOK INDUCTION

## 6.2.2.5 COILS

Remove the appliance casing § [APPLIANCE CASING](#), then the coils can be removed with their supporting paneling. The coil assembly is fixed to the paneling with springs and slots on the supporting panel.

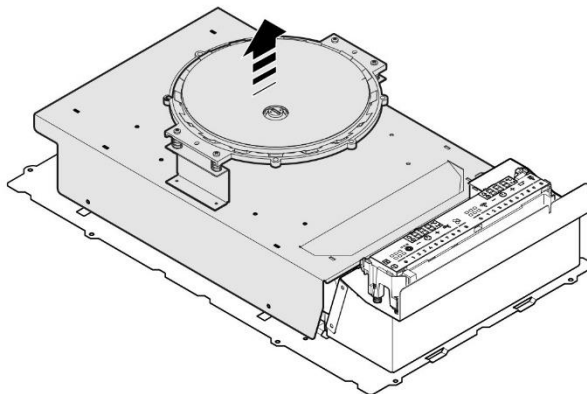

## 6.2.3 COMPONENTS APPLIANCE 5000W

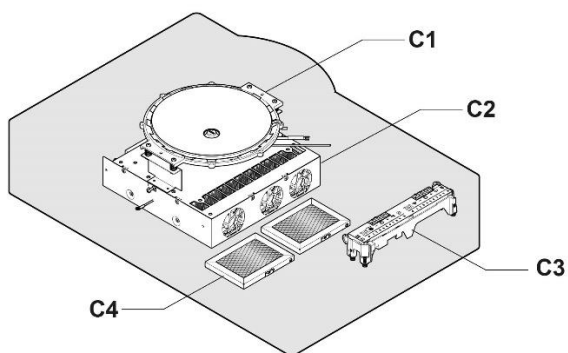

Pos	Component	§.
C1	Generator POB, FOUCAULT	<a href="#">GENERATOR FOUCAULT</a>
B3	Air Filter	<a href="#">AIR FILTERS</a>
B5	User board	<a href="#">USER BOARD</a>



# LIBERO LINE WOK INDUCTION

## 6.2.3.1 GENERATOR FOUCAULT

Remove the appliance casing § APPLIANCE CASING, then:

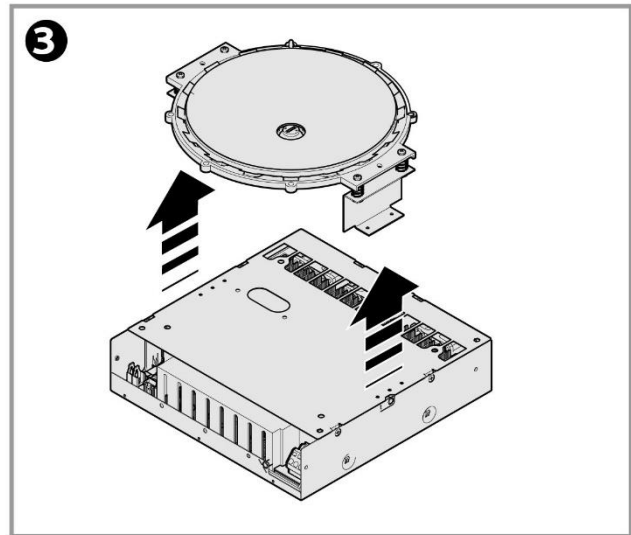
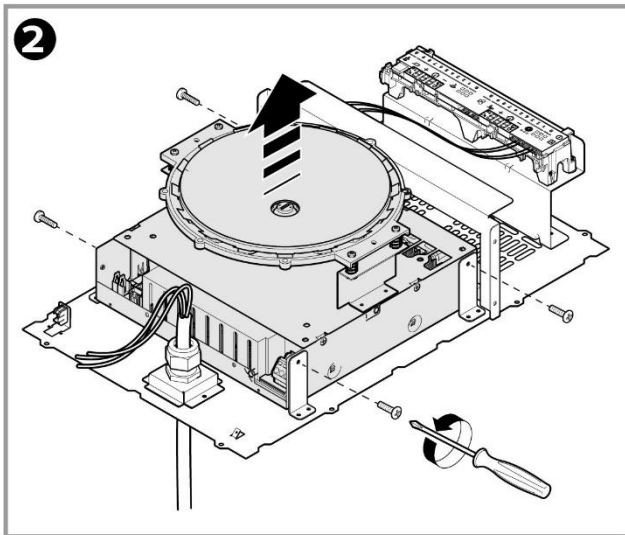
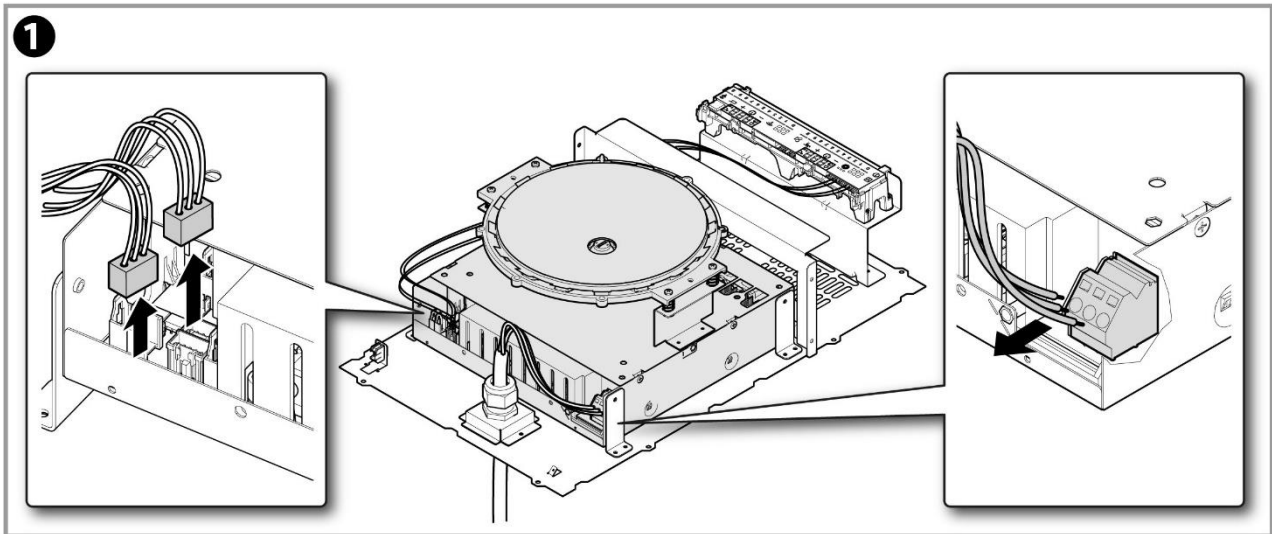

### NOTE !

The coil and temperature probe cannot be dismantled or as separate spare parts.

# LIBERO LINE WOK INDUCTION

## 6.2.3.2 AIR FILTERS

The air filters can be washed separately or inserted into a dish washing machine, dry carefully or leave to dry on a dish rack or towel. In case of clogging up the appliance can over heat and generate an alarm

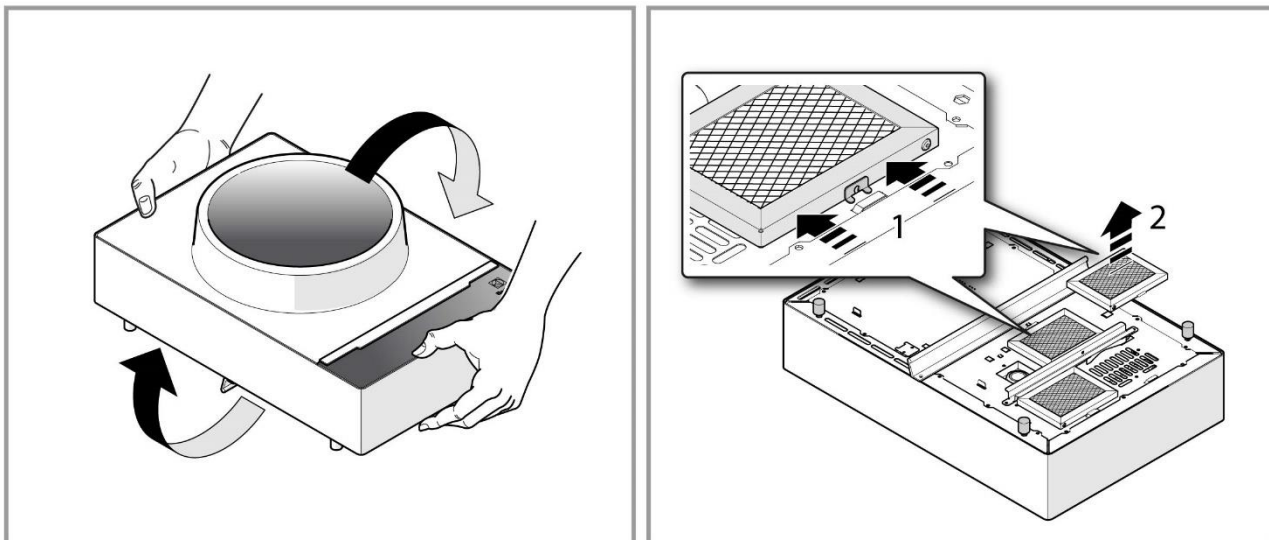

## 6.2.3.3 USER BOARD

Remove the appliance casing § APPLIANCE CASING, then disconnect the supply/communication cables and lift the UI (fix with slots onto the paneling's).

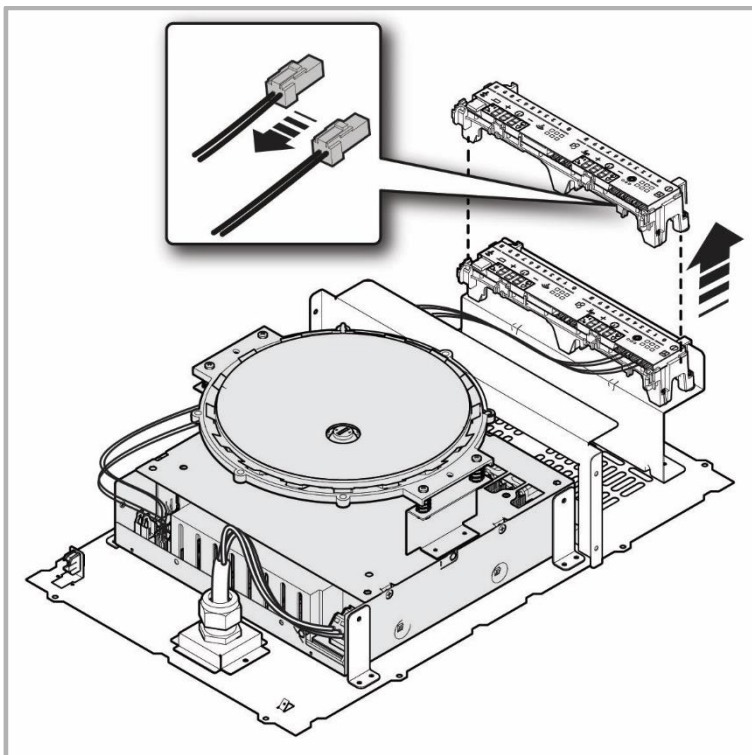

NordCap GmbH & Co. KG  
Thalendorststraße 15  
28307 Bremen  
Hauptsitz (Service, Finanzen & Personal, Lager, IT, Marketing)

Telefon: +49 421 48557-0  
Telefax: +49 421 488650  
E-Mail: [bremen@nordcap.de](mailto:bremen@nordcap.de)

Die NordCap Verkaufsniederlassungen in Deutschland:

Nord: Hamburg • Ost: Berlin • Süd: Ingelheim • West: Erkrath

by **NordCap**<sup>®</sup>

**ZANUSSI**  
PROFESSIONAL